

PD12 IHS / PD12 IDH
(example; exact model may vary)

This instruction handbook is for the daily users of the equipment.

Table of Contents

1	Introduction	3
1.1	The peristaltic principle	3
1.2	Abbreviations in this manual	3
1.3	Symbols on the machine.....	4
1.4	Caution and employee safety.....	4
1.5	Essential training before daily use.....	4
1.6	References	5
2	General information	5
2.1	Unpacking and inspection	5
2.2	Technical specifications	5
3	Installation	6
4	Daily Use	8
4.1	Starting-up and running	8
4.2	Placing the product container.....	8
4.3	Choosing tubes, y-connectors and filling nozzles.....	9
4.4	Assembly of tubes and Y-connectors.....	10
4.5	Mounting of silicone tubes.....	11
4.6	Dispensing.....	12
4.6.1	Prime tubes.....	12
4.6.2	Problems with drips.....	12
4.6.3	Problems with hard feed	12
5	Choice of parameters.....	13
5.1	Programming principle	13
5.1.1	Description of PD12 specific functions/parameters	13
	Function 1 – Volume	13
	Function 2 - Tube diameter	13
	Function 3 - Velocity.....	13
	Function 4 - Acceleration/deceleration	14
	Function 5 - Reversing (back suction)	14
6	Cleaning	15
6.1	Cleaning Frequency.....	15
6.2	Preparations for cleaning	15
6.3	Cleaning Guidance	15
6.4	Detergents or cleaning agents	15
7	Maintenance & service.....	16
7.1	Daily maintenance	16
7.2	Service.....	16
7.3	Methods and frequency of inspections for safety functions	16
8	Interface and change of voltage.....	17
8.1	PD12 interface	17
8.2	Connecting multiple PD12's to flexnet.....	18
8.3	Change of voltage.....	18
9	Declaration of conformity	19

1 Introduction

This manual covers two models.

PD12 IHS (high speed). This model fills one bottle at a time.

In the double head the tubes are mounted in pairs of 2 and via y-connectors these are joined into one tube in order to fill one bottle at a time.

and

PD12 IDH (double head). This model fills two bottles simultaneously.

In the double head the tubes are mounted in pairs of 2 and via y-connectors each set of tubes are joined into one tube in order to fill two bottles simultaneously.

In general all sections of the manual cover both models; unless clearly specified.

1.1 *The peristaltic principle*

PD12 operates with a peristaltic dispenser head (tube pump), where the liquid only comes into contact with the flexible tube, the tube connections and the filling nozzle. The tubes are usually made of silicone, but other materials can also be used.

The dispenser head is designed in such a way that sterilized tubes can be mounted in the head without affecting the sterility.

The dispenser head is self-priming, and the dispenser head itself can stand to be run dry (not recommended for the sake of the tubes).

The dispenser head on PD12 works with four parallel tubes which are squeezed by rollers mounted on ball bearings. The rollers are offset in order to eliminate pulsation.

1.2 *Abbreviations in this manual*

e.g.	As example
Fig.	Figure
Hz	Hertz
i.d.	Internal diameter
IDH	Industrial Double Head
IHS	Industrial High Speed
MC12	Flexicon Master Controller
mA	milli Ampere
msec	milli seconds
o.d.	Outer diameter
PD12	Peristaltic Dispenser
VAC	Volt Alternating Current
VDC	Volts Direct Current

1.3 Symbols on the machine

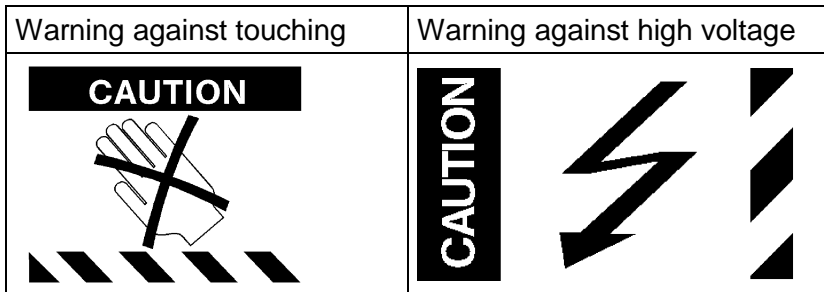

Fig. 1 – Symbols

1.4 Caution and employee safety

This manual should be read before using the PD12.

It is strongly advised that

- Any kind of maintenance or cleaning of the machine not is carried out while power is connected
- Unauthorised / non-trained personnel should not open the cover of the electrical parts
- The machine is placed in such a way that it is not exposed to high humidity, high temperatures or other abnormal operating environment.
- The machine is not to be used in explosion hazardous environments.
- When operating the machine make sure that the dispenser heads are closed and that safety cover is placed above.
- The machine should be used for dosing and filling of liquid fluids, only.

A peristaltic dispenser head is not suitable for viscous products; see section 4.3

1.5 Essential training before daily use

Read the section with *Daily Use*, thoroughly before using the machine.

Protective equipment and protective devices are installed:

- The machine is equipped with a safety cover which protects the operator from hazards; the machine will not run unless the safety cover is placed.
- Always respect the symbols on the machine.

Cleaning must be performed as described in section 6.

1.6 References

- MC12 manual

2 General information

2.1 Unpacking and inspection

Please check that all ordered items have been received and that no items are damaged during transport. In case of any defects or omissions, please contact W-M Flexicon or your supplier immediately.

2.2 Technical specifications

Dimensions:

Length: 525 mm
Width: 200 mm
Height: 208 mm (incl. Feet)



Fig. 2 – Dimensions

Buttons:



online
Lights when communicating with MC12.

power
Lights when the machine is on.

prime
Pushbutton for tube priming

Fig. 3 - Buttons on PD12

Other:

Weight: 13 kg
 Motor: High Torque Step Motor MST341B02
 PD12 Power consumption: max 150 Watt
 Mains: 110/230 VAC earthed, 50/60 Hz

3 Installation

PD12 must be placed on a stable bedplate. All electrical connections are on its rear.



Fig. 4 - Connections

The cable with plug (1) is connected to an earthed switch.

The communication cable from MC12 (type 3) comes fitted with two 4-pin DIN plugs. One is connected to the "net 1" socket (2) on the PD12, and the other plug is connected to the "net" socket on MC12.

The terminator supplied with MC12 (4-pin blind DIN plug) is connected to the "net 2" (3) socket on PD12.

Should the system be operating more than one PD12, the "net 2" socket (3) is to be connected to the "net 1" socket (2) on the next PD12 by a communication cable (type 3). The terminator is connected to the last PD12 on the line.

PD12 is now ready to be switched on and to be programmed from the MC12.

If the PD12 is one of several filling stations in a system, none of the stations may have the same address and it must therefore be changed.

Change of address is performed via a dip-switch placed underneath the PD12. This change may only be carried out when the machine is turned off at the main isolator.

Addresses between 1 and 16 may be chosen, and the table below shows the various combinations.

Address "1" is the factory setting of PD12. This can be changed – see below.



Dip-switch settings:

Address	1	2	3	4	5	6	7	8	9	10	11	12	13	14	15	16
SW1	1	0	1	0	1	0	1	0	1	0	0	1	0	1	1	0
SW2	1	1	0	0	1	1	0	0	1	1	0	1	1	0	0	0
SW3	1	1	1	1	0	0	0	0	1	1	1	0	0	0	0	0
SW4	1	1	1	1	1	1	1	1	0	0	0	0	0	0	0	0

4 Daily Use

4.1 Starting-up and running

Installation section must be carried out before this chapter can be performed.

4.2 Placing the product container

In order to build up adequate pressure, it is recommendable to place the product container at the same level as dispenser head or preferably above the dispenser head level. Placing the container higher than dispenser head level provides positive product support and may reduce the calibration interval. It is also recommended to place the container as close as possible to the dispenser on suction side.

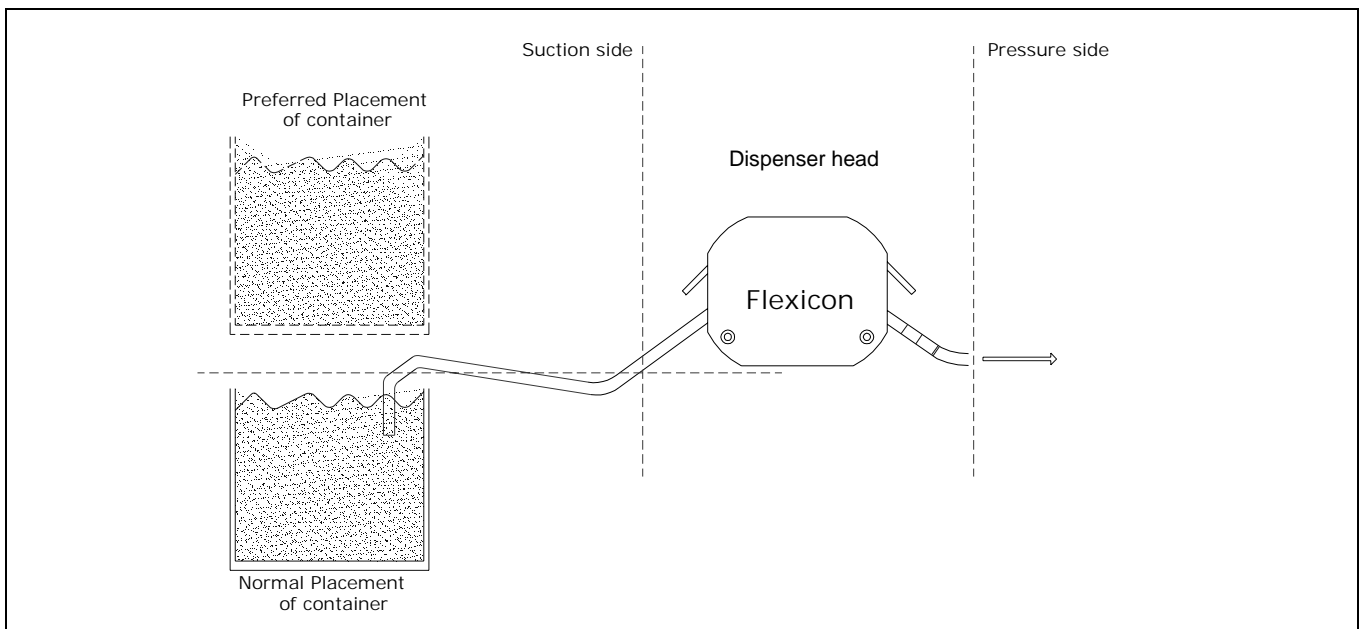

Fig. 5 - placing the product container

4.3 Choosing tubes, y-connectors and filling nozzles

The filling is carried out by the PD12 which is controlled by the MC12.

The capacity is based on the volume to be dispensed, however a lot of factors can influence on the obtainable capacity; e.g. choice of tubes and type of product.

These aspects must be considered before choosing the filling settings.

Tubes must be selected according to the application and volume to be filled. Use the table shown below for choice of tubes according to minimum volume to be filled.

PD12 can operate with different tube dimensions chosen according to the volume to be dispensed. The tubes are designated by their internal diameters (i.d.) in millimetres. This value is always used as designation for the individual tube, and this is also the value to be entered in function 2 at the MC12 master controller.

In order to obtain stable and good results, the choice of tubing can be made according to the following guidelines:

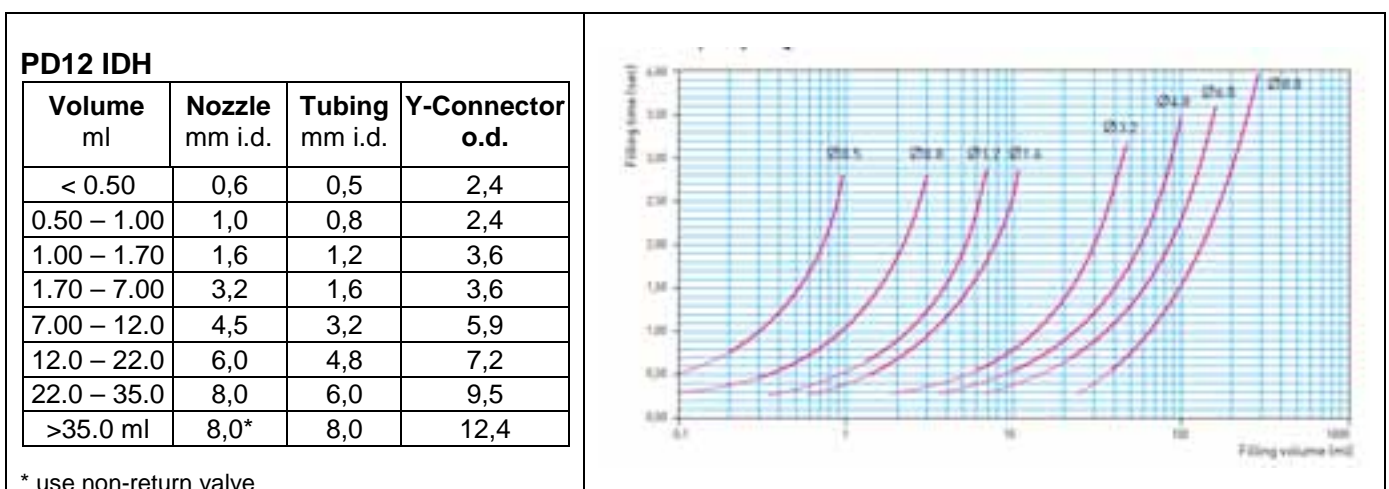
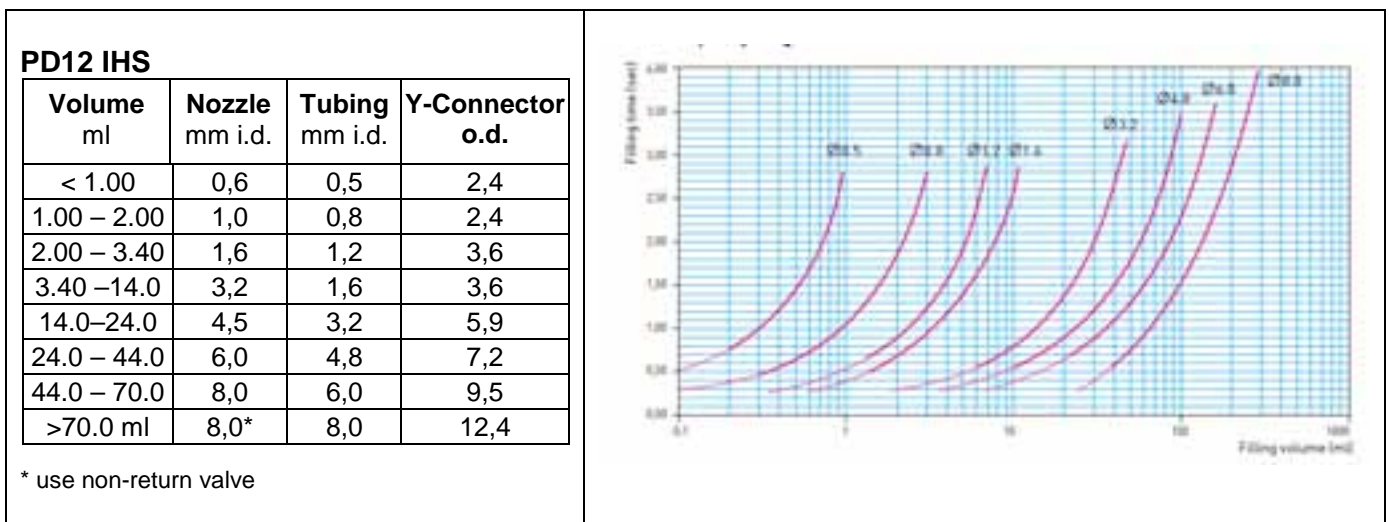

The filling time for a volume of 10.0 ml with a Ø3.2 ID tube is 0.8 seconds with dispenser running in high speed i.e. 400 in rpm and 100 in acceleration.

The same volume can be obtained with Ø4.8 ID tube in 0.55 seconds for the same parameters. The contrast here is outweighed by the fact that Ø3.2 ID tube will in this case yields better accuracy than the option of using Ø4.8 ID. But as it is indicated the capacity will be higher with Ø4.8 tube since filling time is shorter.

The above mentioned example should be considered as guidance only, and adjustments should be done for the individual applications.

4.4 Assembly of tubes and Y-connectors

Before mounting the tubes in the dispenser head the tubes must be assembled with a Y-connector.

When the Y-connector has been assembled, mount the tubes in the dispenser head, as shown in 4.5

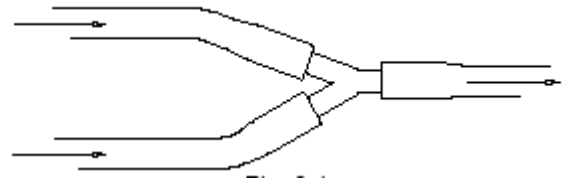

Each set of tubes and y-connector must be assembled as this.

PD12 IHS

PD12 IHS (high speed). This model fills one bottle at a time. In the double head the tubes must be mounted in pairs of 2 and via y-connectors these are joined into one tube.

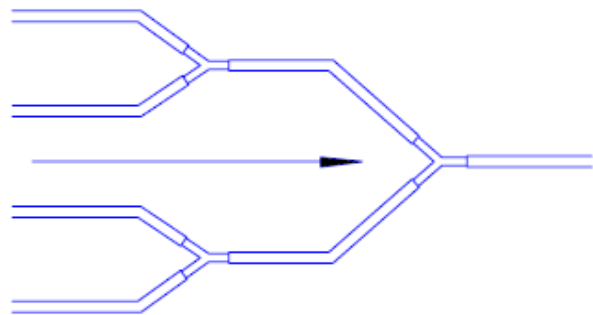

PD12 IDH

PD12 IDH (double head). This model fills two bottles simultaneously. In the double head the tubes must be mounted in pairs of 2 and via y-connectors each set of tubes are joined into one tube.

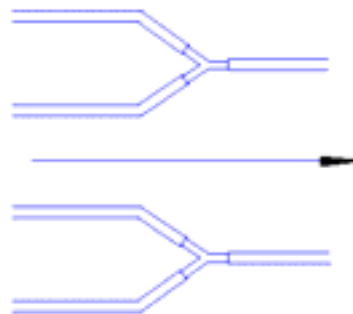

4.5 Mounting of silicone tubes

PD12 is equipped with tube bridges and tube locks. The tube locks ensure that the mounted tubes do not slide through the dispenser head when running.

The tube bridge retains the tube and performs the necessary pressure on the tubes.

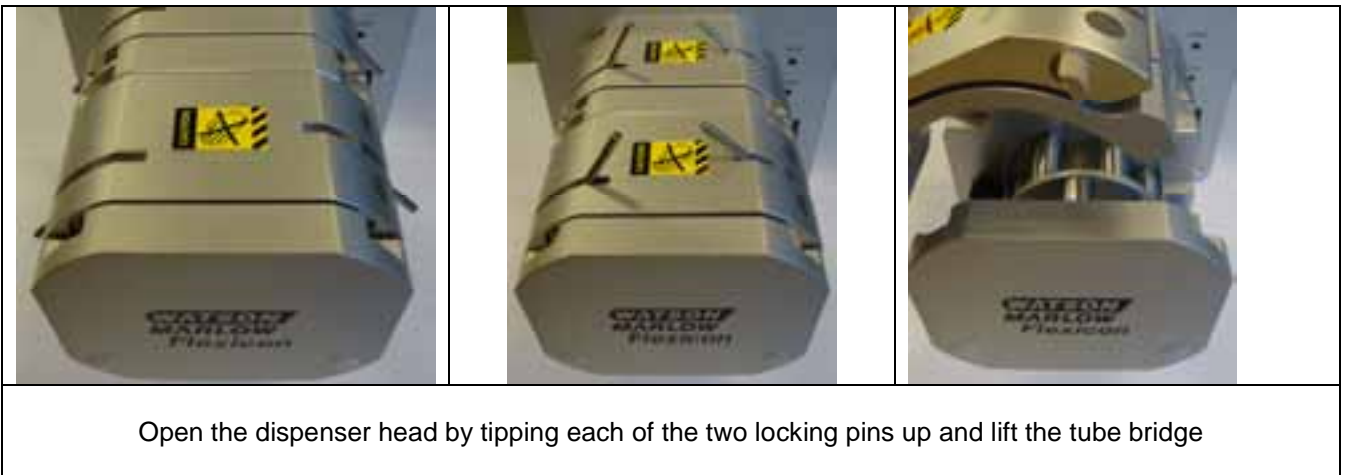

Figure 4-1 Removing the tube bridge

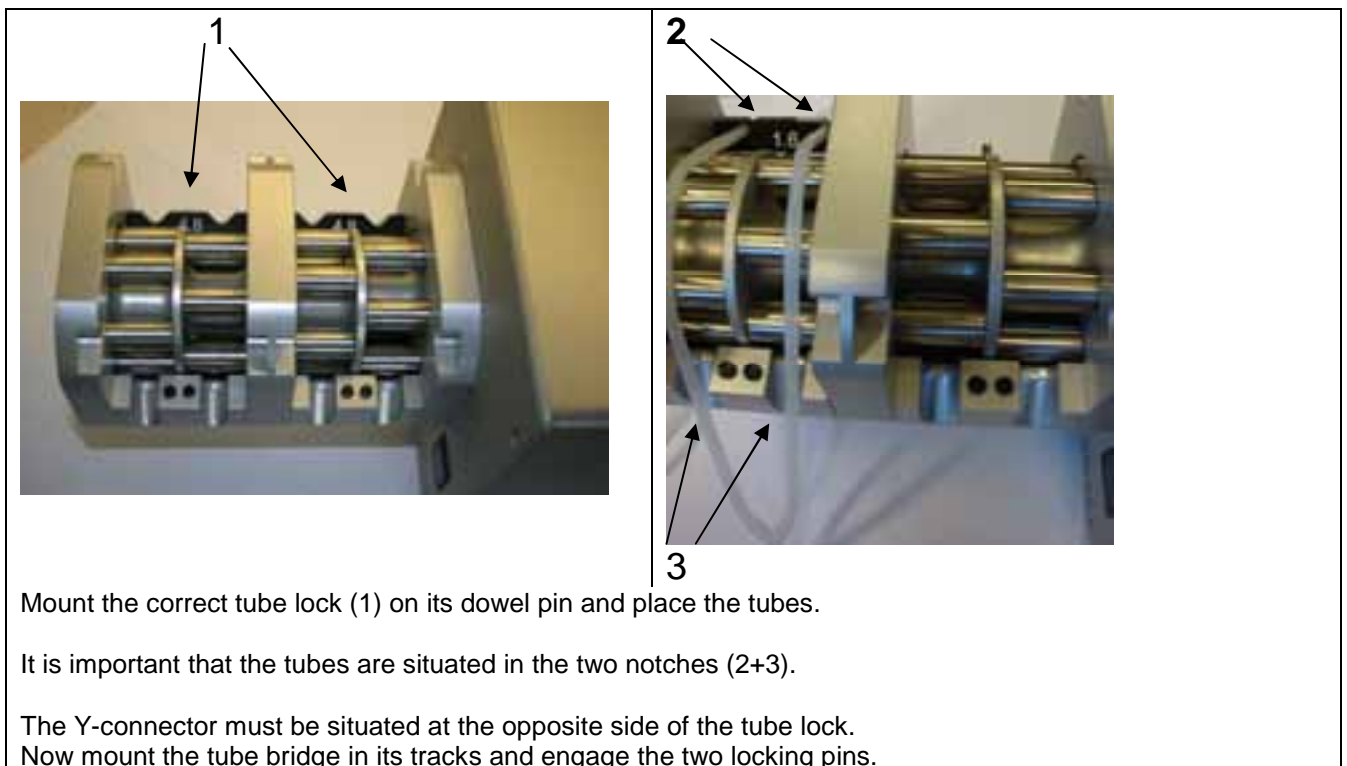

Figure 4-2 Mounting of silicone tubes

*NB! Never leave the dispenser mounted with tubes overnight.
At least tip the locking pins up in order not to retain the tube in pressure.*

4.6 Dispensing

4.6.1 Prime tubes

When the tubes and Y-connectors have been assembled and mounted in the dispenser head, the tubes must be primed; priming tubes have the purpose of filling the tubes with the product.

First, place the product container.

Hold a collecting bowl under the filling nozzle(s) press the prime button.

Check that the tubes are free of bubbles and that the end of the tubes on the suction side, are under the liquid surface. The suction tubes must not have contact with the container body.

4.6.2 Problems with drips

During filling drips can cause incorrect filling volumes and that the area underneath the filling nozzle becomes contaminated. If drips occur the following can be tried:

- choose a smaller filling nozzle
- decrease speed
- increase acceleration
- use reversion
- mount a non-return valve

4.6.3 Problems with hard feed

When dispensing with small tubes, counter pressure on the pressure side of dispenser head might constitute inaccuracy and instability in filling (hard feed). In some cases the problem can be resolved by using a larger tube on the pressure side (after Y-connector).

5 Choice of parameters

5.1 Programming principle

The actual programming will be made on the MC12; however some parameters are PD12 specific.

5.1.1 Description of PD12 specific functions/parameters

The functions below affect filling and calibration.

If the value of the parameter is changed during filling or calibration, the new value will not be applied until the start of the next filling or calibration.

Please note that if parameters are changed during filling a new calibration is recommended.

Function 1 – Volume

Value: ml

Function 1 informs the system of the volume to be filled.

Value		Option
Min	Max	
0.01	9999.9	ml. or gram

The entered value must be between 0.01 and 9999.9.

PD12 IHS:

When entering a volume of e.g. 100 ml, this will be shared among the double heads into 2 x 50 ml.

PD12 IDH:

When entering a volume of e.g. 100 ml, this will trigger each head to fill 100 ml.

Function 2 - Tube diameter

Value: Inside diameter of the tube in mm.

Drive type	Tube inside diameter in mm							
PD12	0.5	0.8	1.2	1.6	3.2	4.8	6.0	8.0

Function 3 - Velocity

Value: Revolutions per minute (rpm).

Velocity range depends on tube size applied.

Range:

Tube Sizes	Max. Velocity	Max. acceleration
0.5 - 0.8 – 1.2 – 1.6	400	100
3.2	400	100
4.8 - 6.0 – 8.0	400	100

The fastest filling will be carried out at the highest velocity setting but the velocity should always be adjusted to suit the characteristics of the product and to reduce splashing or foaming.

Function 4 - Acceleration/deceleration

Value: An integral number.

This function offers a choice of values between 1 and 200 dependent on the tube size and drive; 1 = slowest, 200 = fastest.

Tube Sizes	Max. Velocity	Max. acceleration
0.5 - 0.8 – 1.2 – 1.6	400	100
3.2	400	100
4.8 - 6.0 – 8.0	400	100

Function 5 - Reversing (back suction)

Value: An integral number.

After each filling the dispenser head can be set to perform a small back suction to prevent dripping.

The back suction can be set at values between 0 and 10.

0 = no back suction

10 = maximum back suction

The value has no relation to any other parameters and is solely a number of degrees of a rotor turn. Consequently, the volume that is sucked back will depend on the tube diameter.

For other program possibilities; see the MC12 manual.

6 Cleaning

6.1 Cleaning Frequency

As PD12 is not in direct contact with the dispensed product, daily cleaning might not be necessary.

Cleaning might be determined by local sop's and cleaning validations; but must never be with detergents more potent than the ones below.

6.2 Preparations for cleaning

Before cleaning the machine:

- Turn off the power
- Remove the tubebridge
- Remove the tubes

6.3 Cleaning Guidance

Correct cleaning of the PD12 is carried out by washing it off with water or detergents, using a lint-free firmly wrung cloth or lint-free paper towel; subsequently the machine is wiped off with a dry cloth.

6.4 Detergents or cleaning agents

Normal cleaning agents such as tepid/medium hot water, ethyl alcohol (ethanol) 70% and may be used all over the machine.

The PD12 consists of stainless steel and anodized aluminium, and can be cleaned in several ways:

Cleaning of parts made of:	May be autoclaved	Can be cleaned with ethyl alcohol 70%	Can be cleaned with water and afterwards wiped off with dry a cloth
Stainless steel AISI304	X	X	X
Stainless steel AISI316L	X	X	X
Anodized aluminium	X	X	X
Silicone tubes / Y-connectors	X** Max 10 times	X	X

Examples:

- Flexicon silicone tubes can be autoclaved
- MC12 has a membrane-type keypad. The keypad is sealed and flat and can be cleaned with alcohol or water.

****Recommendation:**

Keep a log on the cleaning in order to keep a sense of perspective.

7 Maintenance & service

7.1 Daily maintenance

PD12 does not require any special daily maintenance, such as lubrication or the like.

7.2 Service

Should service be needed, please contact W-M Flexicon or your local supplier.

7.3 Methods and frequency of inspections for safety functions

Safety functions should be tested once a year:

➤ **Tube Bridge**

Remove the safety cover on the tube bridge and press PRIME.

The machine must not start if the safety cover is not present.

Keep a log and read the previous log recordings to present an overview of the machines state. After testing the safety functions the results must be recorded in the log.

8 Interface and change of voltage

8.1 PD12 interface



1 = External 1:	
PIN 1:	INPUT FOR START SIGNAL +5 - 50 VDC, min. 100 msec. positive-edge-triggered.
PIN 2:	OUTPUT, +24 VDC, MAX. 500 MA.
PIN 3:	GROUND.
PIN 4:	STATUS OUTPUT, MAX. +24 VDC, 100 MA. Pin 4 is grounded via an open collector during filling.
PIN 5:	STATUS OUTPUT, MAX. +24VDC, 100 mA Pin 5 is complementary to pin 4.
2 = External 2:	
PIN 1:	INPUT FOR DISABLING. +5 - 50 VDC. if this pin is activated, the drive will be disabled (no dispensing).
PIN 2:	OUTPUT, +24 VDC, MAX. 500 MA.
PIN 3:	GROUND.
PIN 4:	STATUS OUTPUT, MAX. +24 VDC, 100 MA. Pin 4 is grounded via an open collector during filling.
PIN 5:	STATUS OUTPUT, MAX. + 24 VDC, 100 MA. Pin 5 is complementary to pin 4.
3 = Net 1	This socket is reserved for (RS-485) network communication.
4 =Net 2	This socket is reserved for (RS-485) network communication.

8.2 Connecting multiple PD12's to flexnet

Connection of PD12P's in Flexnet

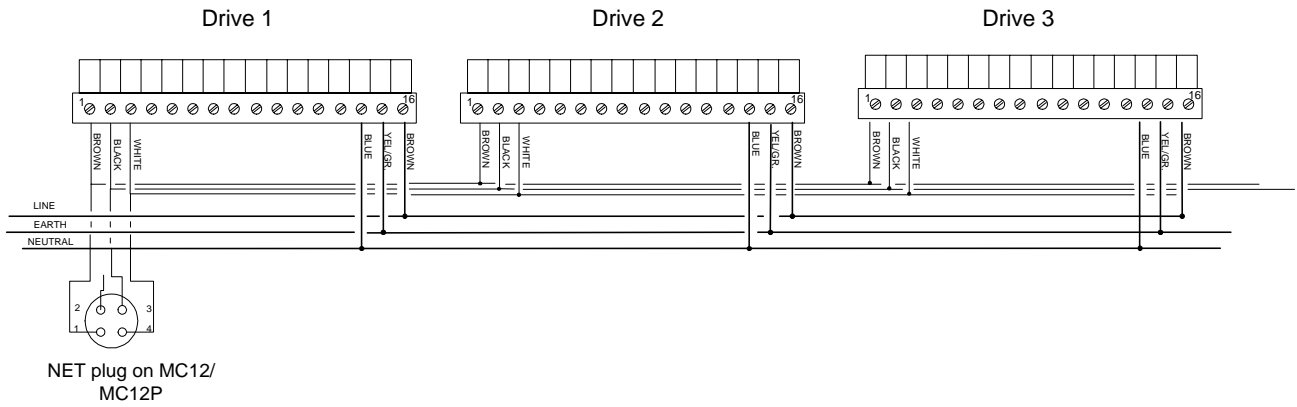

8.3 Change of voltage

The PD12 can be converted to accept another supply voltage.

The conversion can be made inside the machine by moving the cables of the transformer clamps.

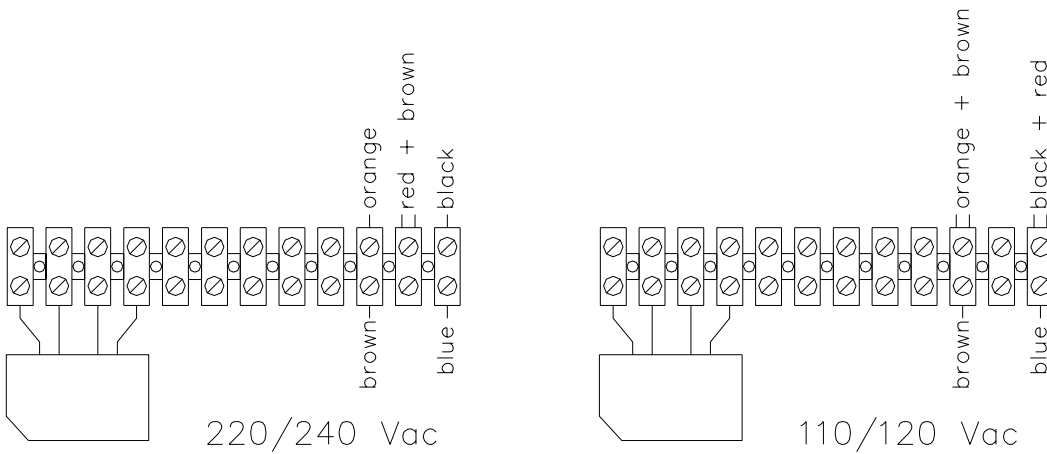

9 Declaration of conformity

We Watson-Marlow Flexicon A/S
 Frejasvej 2-6
 DK-4100 Ringsted

Declare on our sole responsibility that the product:

Peristaltic dispenser: **PD12 IHS / PD12 IDH**
Model: **61-154-014**

To which this declaration relates is in conformity with the following standard(s):

DS EN/ISO 12100	Safety of machinery - Basic concepts, general principles of design
DS/EN 60204	Safety of machinery – Electrical equipment of machines

According to the provisions in the Directives:

2006/42/EC	On the approximation of the laws of the Member States relating to machinery
2006/95/EC	On the harmonization of the laws of Member States relating to electrical equipment designed for use within certain voltage limits
2004/108/EC	On the approximation of the laws of the Member States relating to electromagnetic compatibility

Signature:



January 2011

Ringsted, Denmark

Jørn Jeppesen, Development Manager