

OPERATOR'S MANUAL

FlexSeal 10 & 32

DECLARATION OF CONFORMITY	3
CAUTION	4
1. GENERAL INFORMATION	4
2. INSTALLATION	5
3. CONTROL SWITCH	6
4. ADJUSTING THE HEIGHT	7
5. ADJUSTING STROKE LENGTH OF PISTON IN CLOSING HEAD	9
6. CHANGING THE CAPPING HEAD	10
7. DAILY USE	11
7.1 DAILY CLEANING	12
7.2 MAINTENANCE	12
7.3 DISPOSAL	12
8. ACCESSORIES	12
9. TECHNICAL SPECIFICATIONS:	13
ANNEX A:	14
ANNEX B:	14
ANNEX C:	15

DECLARATION OF CONFORMITY

We Flexicon A/S
Frejasvej 2-6
DK-4100 Ringsted

declare on our sole responsibility that the products:

FlexSeal 10 and FlexSeal 32

to which this declaration relates are in conformity with the following standard(s):

EN 292: Safety of Machinery: Basic Concepts, General Principles of design.

according to the provisions in the Directives:

98/37/EEC, 91/368/EEC and 93/44/EEC: Machine-directive.

73/023/EEC: Low Voltage-directive

EMC 89/336/EEC

Ringsted June 2006

Mads Ulric Jensen
Signature



CAUTION

This manual should be read before using the FlexSeal.

Explanations to the pictograms:

:

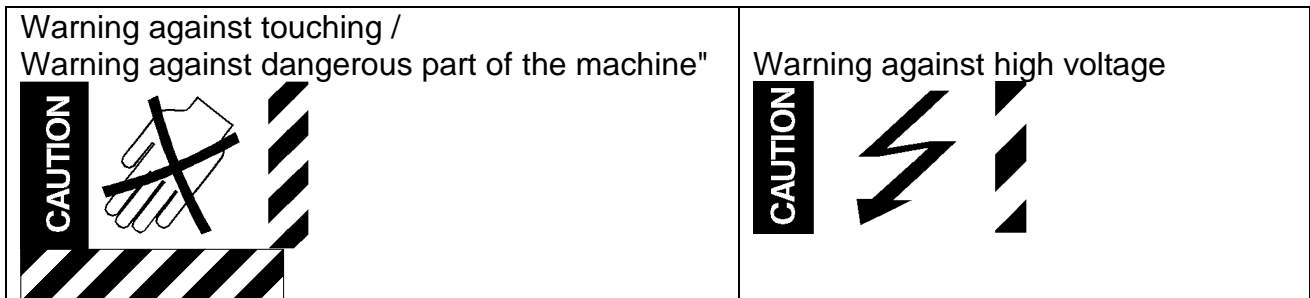

The capping head should be adapted to the size of the bottle cap.

The bottle centre tool should be used for capping bottles less than 55 mm high (Annex C).

The mains switch is used for emergency stopping.

FlexSeal should only be used for capping bottles.

The FlexSeal must be placed on a stable bed plate and in such a way, that it is not exposed to great humidity, high temperatures or other abnormal operating environments. It is not to be used in explosion hazardous environments.

It is prohibited to maintain or clean the FlexSeal, when it is connected to the power supply.

It is prohibited for unauthorised personnel to open the cover of the electrical parts of the FlexSeal.

Always remember that the FlexSeal must be earthed through the main switch.

1. GENERAL INFORMATION

FlexSeal is a semiautomatic machine for crimping aluminium caps on vials. By changing the closing head, different cap type can be crimped.

Please check that all items have been received, and that no items were damaged during transport. In case of any defects and shortcomings, please contact Flexicon or your local supplier immediately.

When ordering spare parts or accessories for FlexSeal, please state the serial number. The serial number is stamped on a label on the rear of the FlexSeal.

2. INSTALLATION

Please check that, the machine is made for your local power supply. The sign on the machine indicates the value of power (110/120 VAC or 220/240 VAC). The frequency has no influence.

If the delivered power cable does not match your plug, the power cable is mounted in the right plug. The cable must be mounted as following:

Brown	Phase
Blue	Neutral
Yellow/Green	Earth

REMEMBER that the machine must always via the power plug be connected to the earth and connected to CLEAN and DRY compressed air.

Due to the safety it is imperative that the earth connection is correctly established.

The plug box (E) contains 2 fuses. When the cover of fuse box is removed 1 more fuse is found inside the machine.

Connect the 5-7 clean and dry compressed air to the pipe stub (P). Connect the power to the plug box (E) and the machine is ready for use.

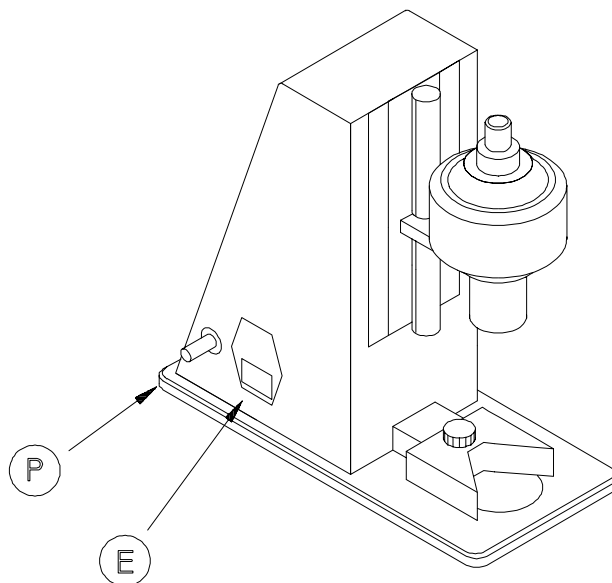

Fig. 1

3. CONTROL SWITCH

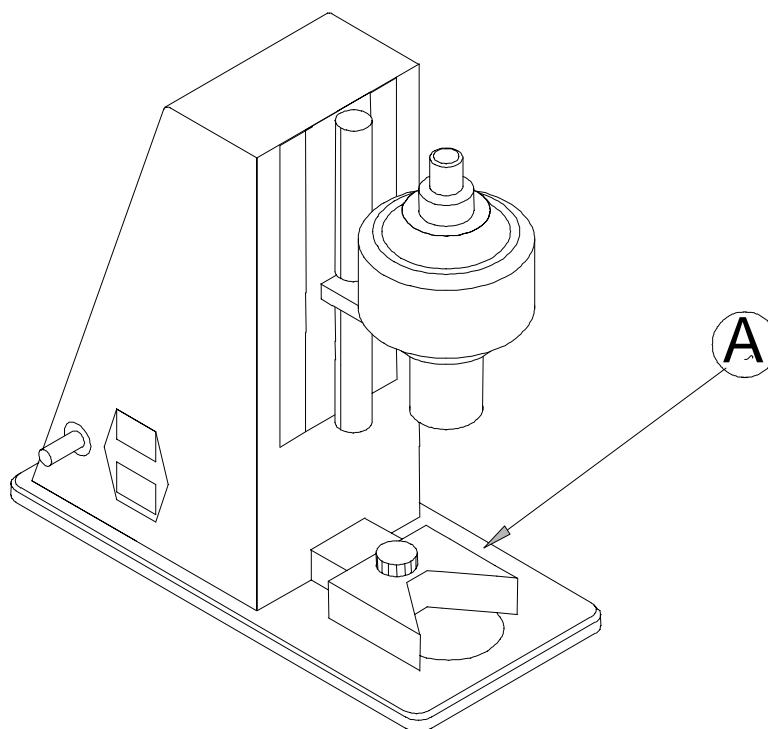

Fig. 2

On the base plate of the FlexSeal you find the bottle grip switch (A) which activates the closing sequence, when it is pushed towards the machine.

4. ADJUSTING THE HEIGHT

Before starting the production the initial height of the capping head and the bottle holder should both be adjusted.

Begin with the bottle holder.

1. For safety reasons switch the power OFF
2. place a bottle on the base plate under the capping head.
3. Loosen height adjustment screw "B" and lower the capping head so it is just above the bottle neck.
4. Now adjust the bottle holder so the bottle is centred under the capping head – **WHEN THE BOTTLE HOLDER IS PUSHED "IN"** (see fig 3)
5. Now FS10 is ready for height adjustment.

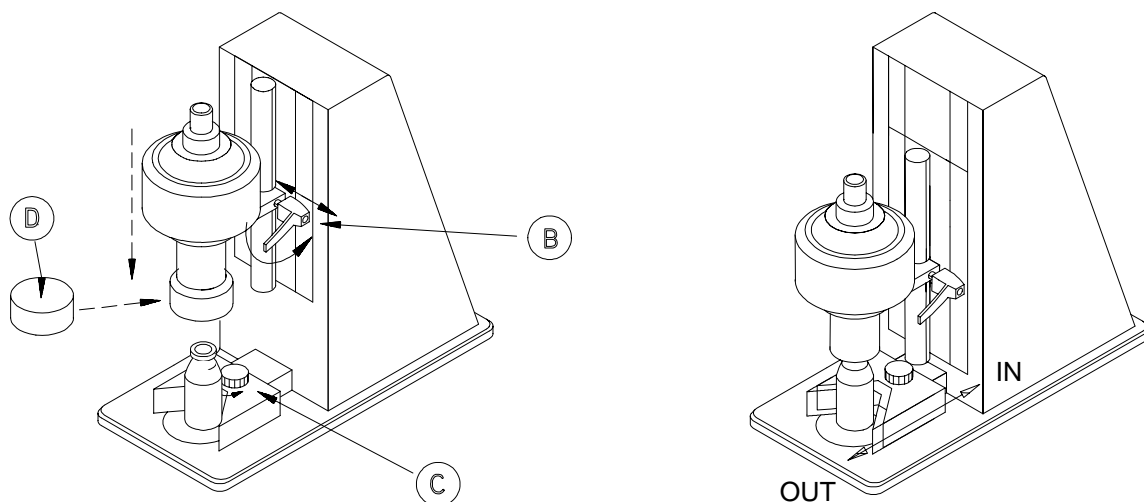

Fig. 3

Connect compressed air and power. Turn power ON.

Choose the spacer (D) which best fits the crimp head on the machine.

Place a bottle under the crimp head – With NO stopper or cap in place.

Place the spacer on the crimp head, so that spacer fits on the crimp head.

Loosen the handle (B), press the capping head down until it rests firmly on the bottle. It should be so firm, that the bottle can only be removed by the use of some force.

Tighten height adjustment handle (B) again. Remove bottle and spacer. The height is now roughly adjusted.

For final adjustment, a few vials should be capped and crimped.

Examine the results and if necessary make adjustments according to trouble shooting scheme on the next page.

Trouble shooting

Problem:	Crimping leaves marks on the cap skirt, and crimping is not tight.
Reason:	Capping head is too high.
Action:	Lower capping head.

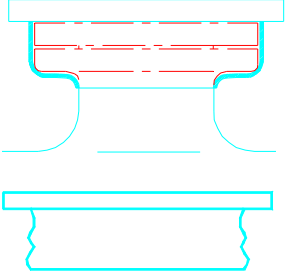
Problem:	Caps are closed on the bottle neck. Or the caps are deformed. (harmonica deformation)	
Reason:	Caps skirts are too long for stopper-vial combination. Too long stroke.	
Action:	Check combination of rubber stopper, vial and cap. Adjust the stroke. (see next page)	

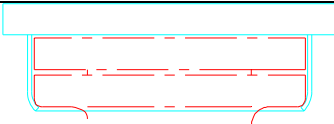
Problem:	Crimping is done on the rim of caps.	
Reason:	Too short stroke. Cap skirt is too short.	
Action:	Make an adjustment of the stroke. Check rubber stopper's head for thickness.	

Problem:	Cap is not crimped tight. Cap is crimped too tight.	
Reason:	Incorrect height of crimp head. Stroke length incorrect. Dirty/worn jaws.	
Action:	Adjust the crimp head height slightly. Lower is tighter – Higher is looser. Make an adjustment of the stroke. Clean and polish the jaws.	

5. ADJUSTING STROKE LENGTH OF PISTON IN CLOSING HEAD

Under normal condition it is possible to operate with full stroke length on the piston, but in certain combination of cap and bottle ring tolerances, the cap might fold when hitting the bottle neck.

If the above occurs, the stroke length can be adjusted as following:

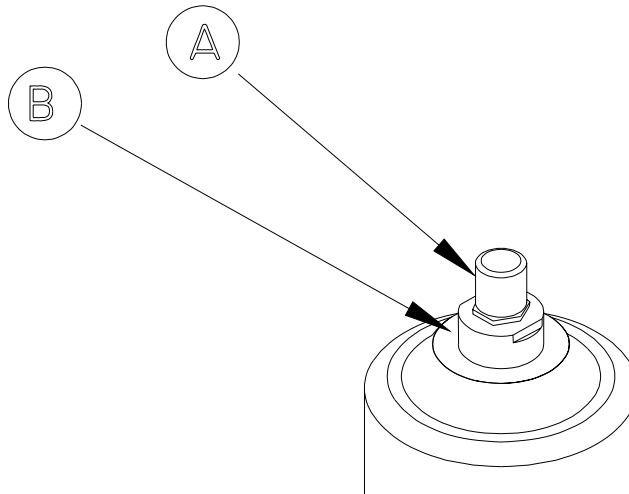

Fig. 4

1. Loosen the nut fig. 4 (A) and screw down the piston cap (B).
2. While holding contra on the piston cap with the key surface, the nut is tightened.
3. Repeat the procedure until the cap is crimped satisfactory.

6. CHANGING THE CAPPING HEAD

In case the machine should operate with another type of cap than the standard one the head is changed as described below:

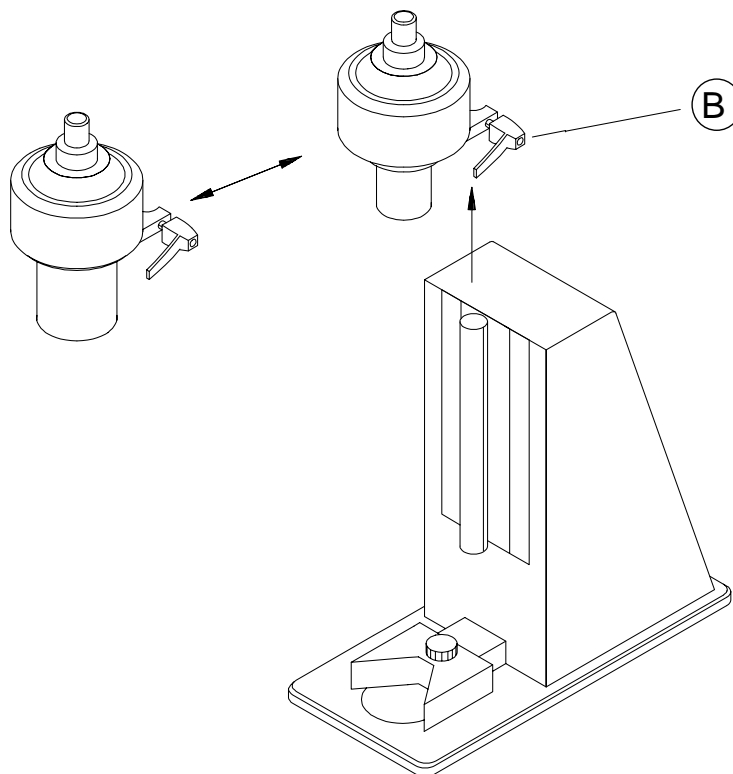

Fig. 5

1. Switch off the main power and disconnect the compressed air.
2. Take off the 2 tubes by releasing Snap-Joint fitting.
3. Loosen the handle (B) and pull up the closing head over the retaining bar.
4. The new capping head is pushed down over the retaining bar.
5. Connect the tubes. The upper tube goes to the upper fitting.

The new capping head is now mounted and adjustment is carried out as described earlier.

7. DAILY USE

The bottle with cap is placed in the bottle grip, which is activated by pressing it towards the rear of the machine. The closing head moves down onto the cap and bottle.

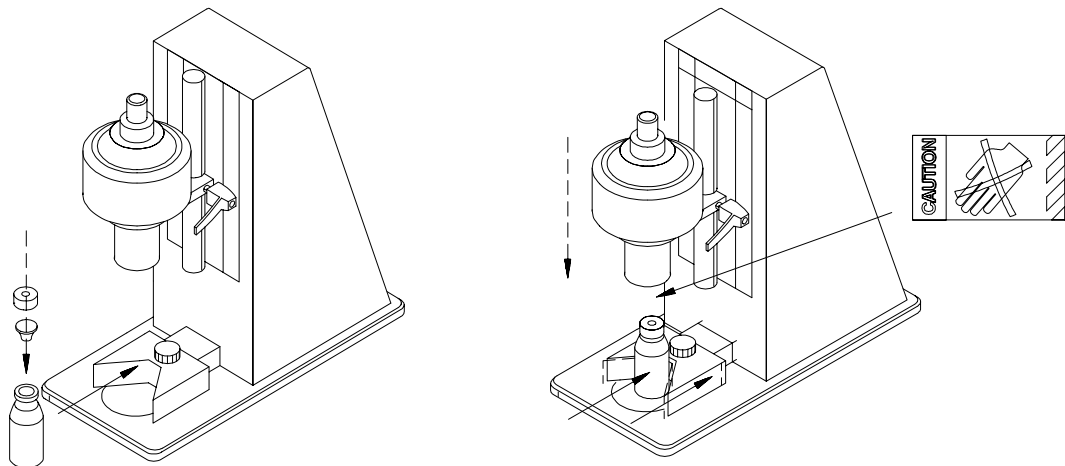

Fig. 4

The bottle grip activates a micro switch which releases the compressed air used to hold the closing head. The head then descends on the cap by its own weight.

In case something prevents the crimping head (e.g. a finger) in encircling the cap, a stroke will not be achieved.

When the closing head is in position over the cap, a micro switch is activated in order to activate the jaws of the closing head.

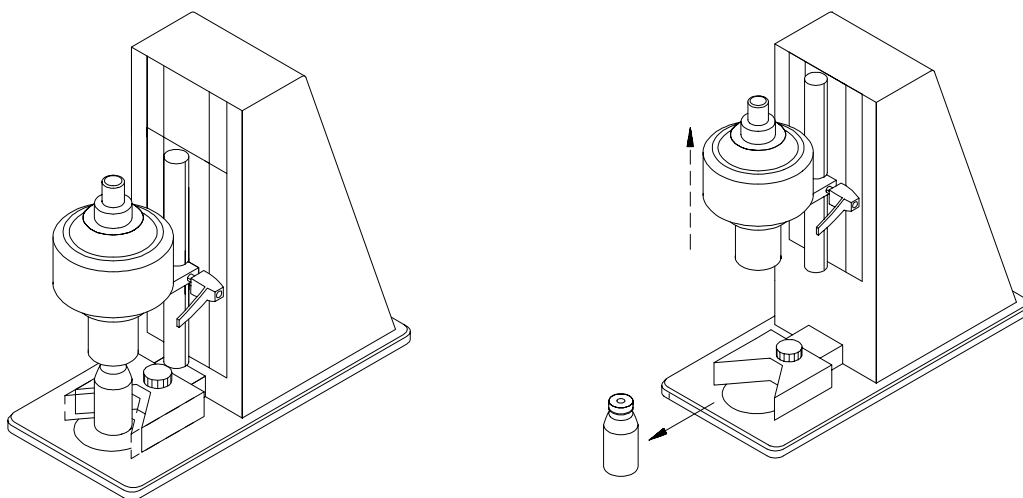

Fig. 5

The jaws cap the bottle and the closing head returns to its upper position.

7.1 Daily cleaning

Daily cleaning will not be necessary except for the normal routine cleaning of production equipment. Liquids are NOT to be splashed onto FlexSeal. It should only be cleaned with a damp piece of paper tissue or cloth.

7.2 Maintenance

As all movable parts in FlexSeal are maintenance-free, no maintenance is required apart from normal cleaning of the equipment.

If service should be needed, please contact your supplier or [Flexicon A/S](#).

7.3 Disposal

The machines can be disposed in the same way as Personal Computers.

8. ACCESSORIES

For FS10 a number of standard closing head is made as well as closing head for special purposes. The mounted standard grip covers most bottle sizes, but customised bottle grip can also be delivered.

Closing heads	Order No.
13 mm DIN standard	89-100-013
13 mm DIN with Flip -Top	89-100-014
20 mm DIN standard	89-100-020
20 mm DIN standard	89-100-021
FS32 only 32 mm DIN standard	89-120-010
Bottle grips	
FS10 special size	89-100-50
FS10 Ø14-Ø38	89-100-51
FS10 Ø35-Ø63	89-100-52
FS10 Ø57-Ø73	89-100-53
FS32 special size	89-120-050
FS32 Ø20-Ø51	89-120-051
FS32 Ø45-Ø76	89-120-052
FS32 Ø70-Ø97	89-120-053

9. TECHNICAL SPECIFICATIONS:

		FS10	FS32
Power supply:	110/240 VAC 50/60 Hz, earthed.		
Power Consumption:	Max. 50 W		
Air Supply:	6 bar clean and dry air	35 L/min	50 l/min
House:	Anodised aluminium		
Jaws and piston:	CrNi-steel		
Ingress protection	IP31		
	Weight	12 Kg	16 Kg
	Cap size	8 -20 mm DIN	20-32 mm DIN
	Bottle height	180 mm.	240 mm.
	Max diameter	55 mm.	95 mm

Annex A:

	Flexicon [®]	2003
Model:		
Serial No.:	ååuu-lbnr	
Supply:	230V / 50/60Hz / 1200W	
CE	Made in Denmark	

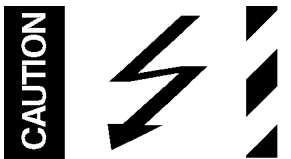

Annex B:

Sound pressure level: $L_{Aeq} < 70$ dB(A)

Annex C:

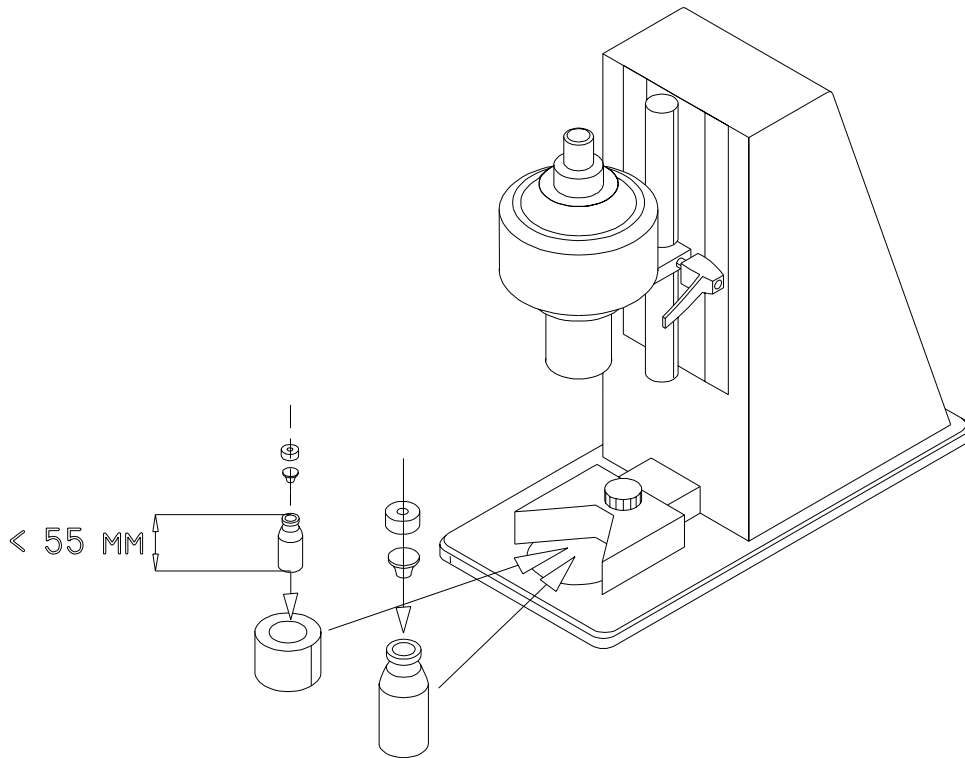

COPYRIGHT

Copyright (c) 2006 Flexicon A/S. All rights to this manual belong to Flexicon A/S. Neither the complete manual nor parts of it may be translated, copied, printed or published in any form or by any means without written permission from Flexicon A/S

Flexicon A/S is convinced that the information of this manual is correct, but Flexicon A/S can not be held responsible for it.

Flexicon A/S reserves the right to update and amend this manual without previous notice. Flexicon A/S is under no obligation to update manuals already published.