

<b>WATSON MARLOW Flexicon</b>	<b>PD12 OEM Installation Manual</b>		
Re.: Installation	Rev.: 1.03	Date: 2008-05-30	Page 1 of 14

***Installation Manual***

***Peristaltic Dispenser***

***PD12 OEM***

	<b>PD12 OEM Installation Manual</b>		
<b>Re.: Installation</b>	<b>Rev.: 1.03</b>	<b>Date: 2008-05-30</b>	<b>Page 2 of 14</b>

## 1 Table of Contents

<b>1</b>	<b>Table of Contents</b> .....	<b>2</b>
<b>2</b>	<b>Installation - General</b> .....	<b>3</b>
<b>3</b>	<b>Installation of PD12 OEM dispenser head and control unit</b> .....	<b>4</b>
3.1	Installation of PD12 OEM dispenser head .....	4
3.2	Installation of PD12 OEM control unit .....	6
<b>4</b>	<b>Electrical connection of PD12 OEM</b> .....	<b>7</b>
<b>5</b>	<b>Integration of the PD12 OEM into the filling machine control system</b> .....	<b>8</b>
5.1	Stepper Motor Connector – X1 .....	9
5.2	Inputs Connector – X2 .....	10
5.3	Outputs Connector – X3.....	11
5.4	X4 Mains supply connector .....	11
5.5	Addressing of filling station .....	12
5.6	Connection to NET connector on Master Controller MC12.....	12
<b>6</b>	<b>Selection of internal or external supply for Controller PCB</b> .....	<b>13</b>
<b>7</b>	<b>Change of voltage</b> .....	<b>14</b>
7.1	Change of voltage .....	14
<b>8</b>	<b>Copyright</b> .....	<b>14</b>

	<b>PD12 OEM Installation Manual</b>		
<b>Re.: Installation</b>	<b>Rev.: 1.03</b>	<b>Date: 2008-05-30</b>	<b>Page 3 of 14</b>

## 2 Installation - General

This manual only relates to incorporation of the PD12 OEM into a filling machine.

Please refer to PD12 OEM operator's manual and MC12 operator's and reference manuals for daily use of the PD12 OEM.

The installation of the PD12 OEM consists of

- Installation of dispenser head and control unit
- Electrical connection of the various parts of the filling system
- Integration of the PD12 OEM into the filling machine control system

<b>WATSON</b> <b>MARLOW</b> <i>Flexicon</i>	<b>PD12 OEM</b> <b>Installation Manual</b>		
<b>Re.: Installation</b>	<b>Rev.: 1.03</b>	<b>Date: 2008-05-30</b>	<b>Page 4 of 14</b>

### 3 Installation of PD12 OEM dispenser head and control unit

#### 3.1 Installation of PD12 OEM dispenser head

The dispenser head must be mounted through a solid wall. The wall must have a thickness of 17 to 19 mm.

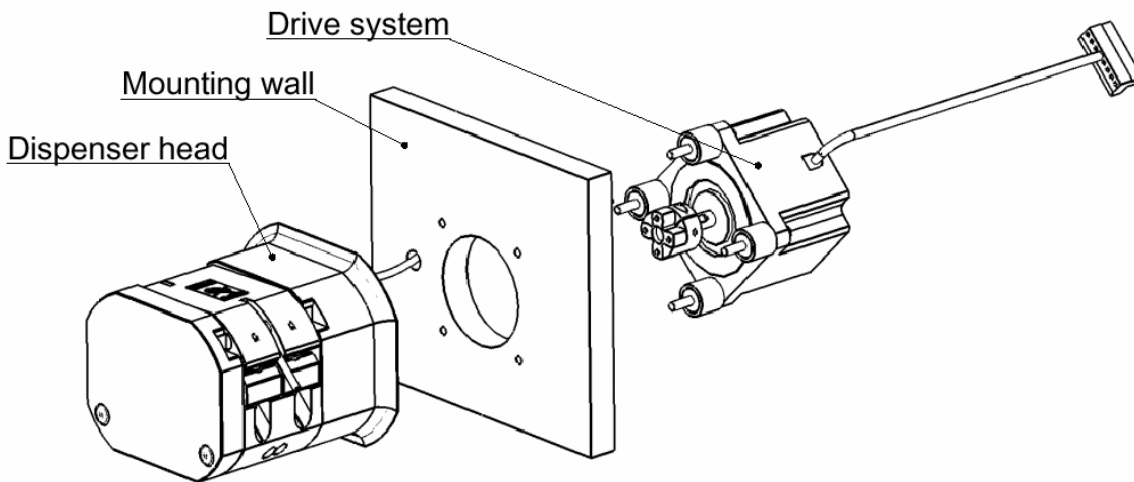

**Fig. 3-1**

The dispenser head can be mounted in either vertical or horizontal position. The only orientation that cannot be used is horizontal with the tube bridge facing downwards. All other orientations will not affect the performance of the dispenser.

It must be observed that sufficient space around the dispenser head is available to allow change and positioning of tubes. These minimum distances must also be observed, when installing more than one dispenser in the same wall.

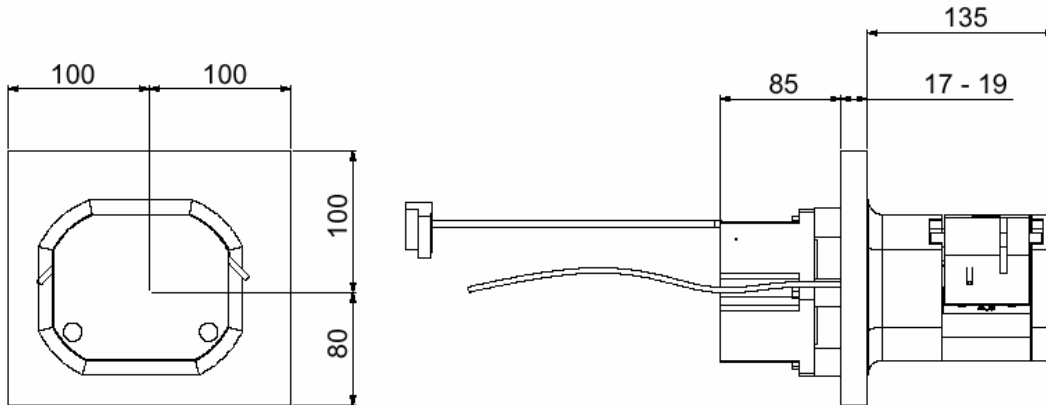

Fig. 3-2

Also the length of the dispenser head in front of the wall and the depth of the drive system behind the wall must be observed to allow mounting and service of the dispenser.

Use dimensions below for mounting holes.

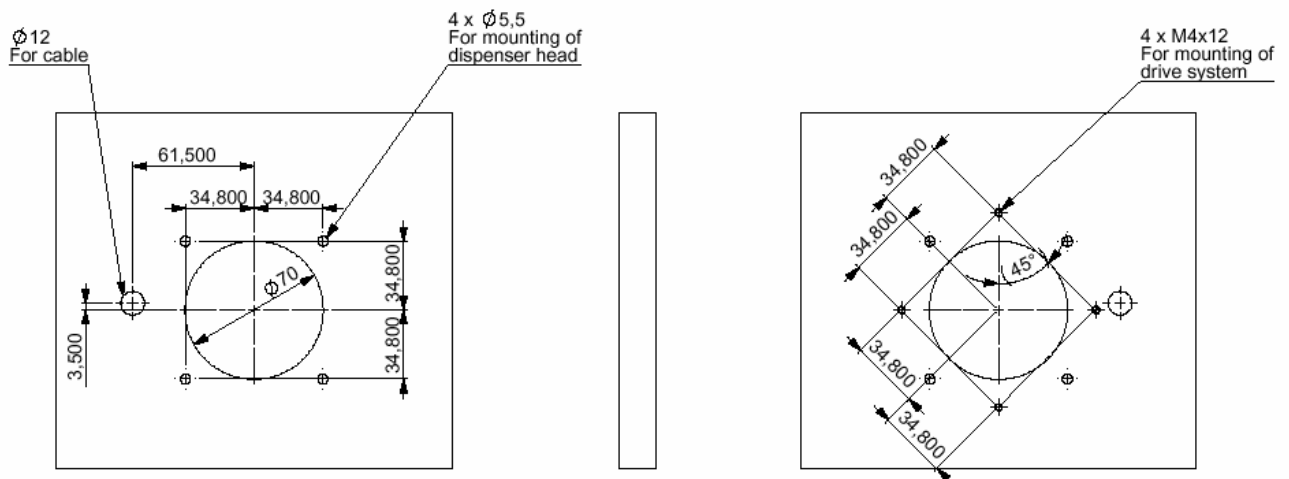

Fig. 3-3

### 3.2 Installation of PD12 OEM control unit

The PD12 OEM control unit is intended for mounting on a flat vertical surface inside the filling machine control cabinet. The control unit is intended for mounting on 3 pcs M6 Allen screws with cylindrical head.

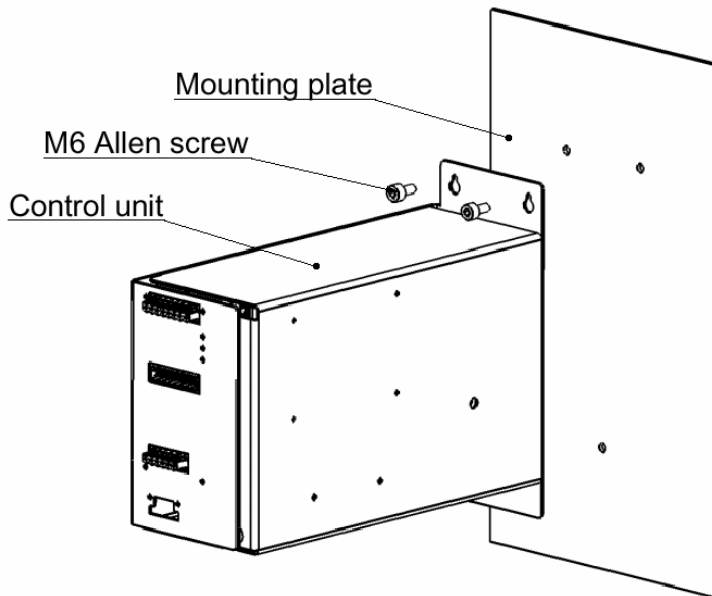

Fig. 3-4

It must be observed that sufficient space around the control unit is available to allow mounting of the unit and ventilation. The rear side of the control unit, that contains all electrical connections, must be accessible.

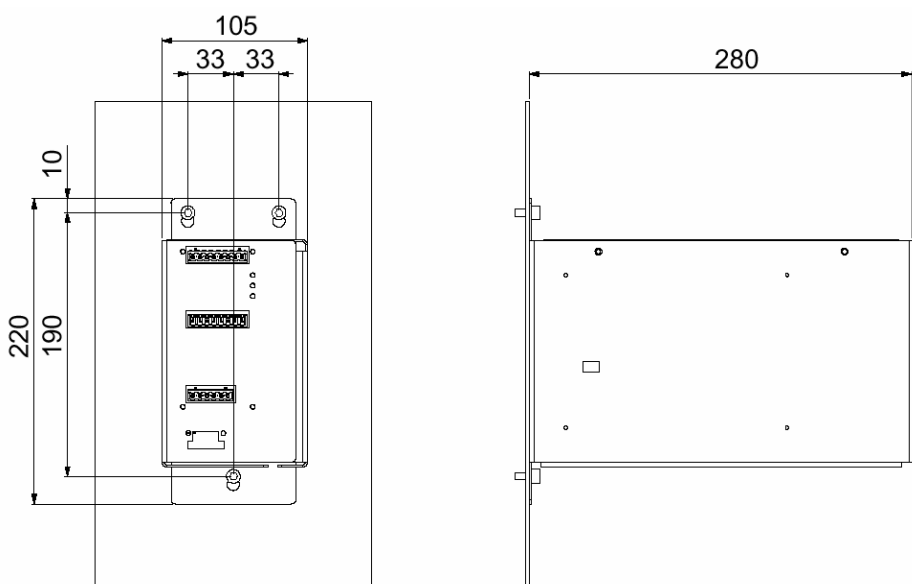
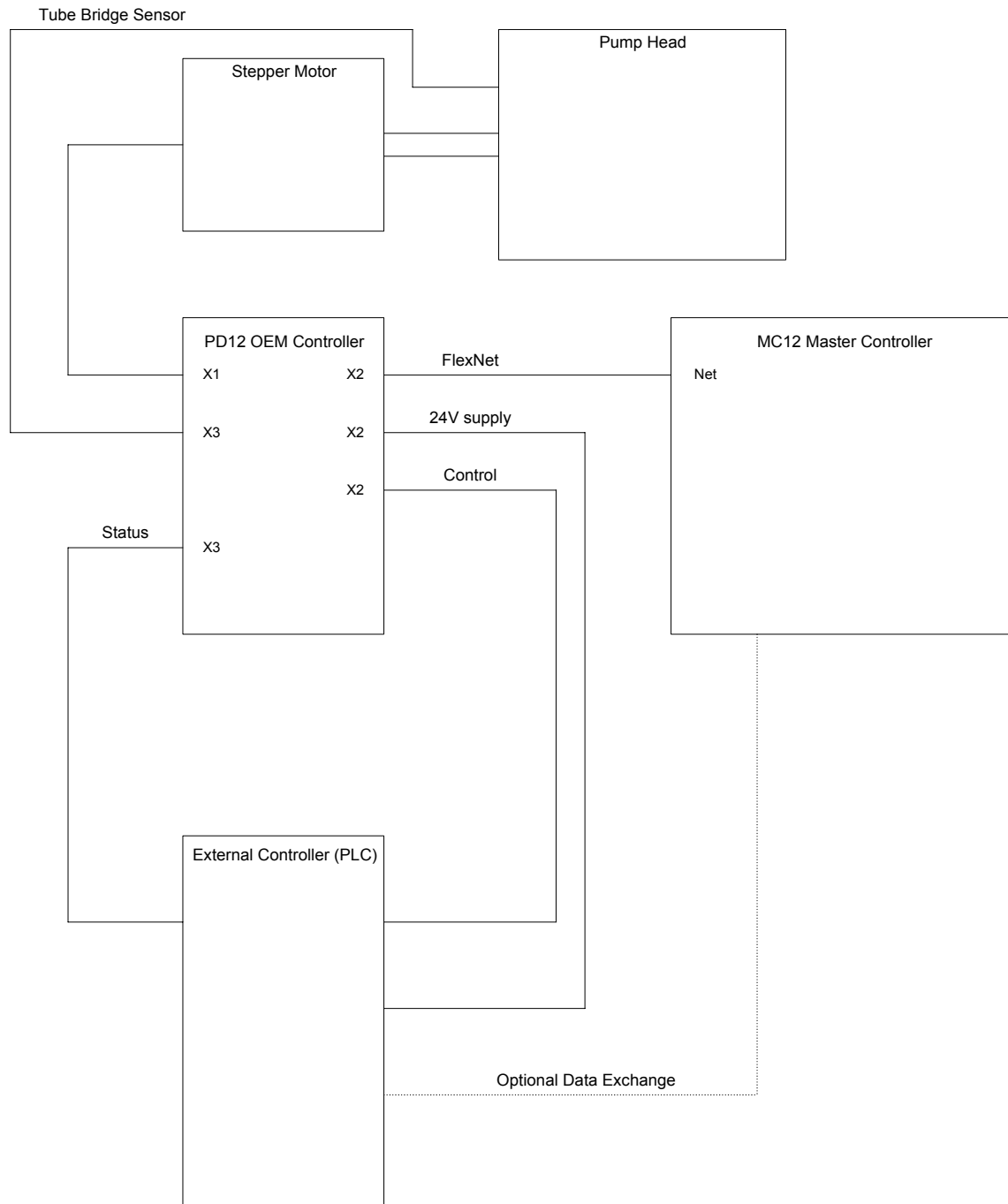

Fig. 3-5

## 4 Electrical connection of PD12 OEM

The various parts of the filling system must be connected as shown in the connection block diagram below.

All necessary connectors are supplied with the machine, but cables are not included. Use 8 x 0,5 mm<sup>2</sup> wire for cable between stepper motor and controller.



**Fig. 4-1**

Each connector and corresponding electrical and functional specification is described in the following section.

## 5 Integration of the PD12 OEM into the filling machine control system

Integration of the PD12 OEM into the filling machine control system must be carried out according to the technical description of the electrical interface below.

The PD12 OEM has the electrical interface on the rear side of the cabinet. It consist of 4 PHOENIX connectors, connecting to Stepper Motor, Inputs, Outputs and Mains power.

### Rear view

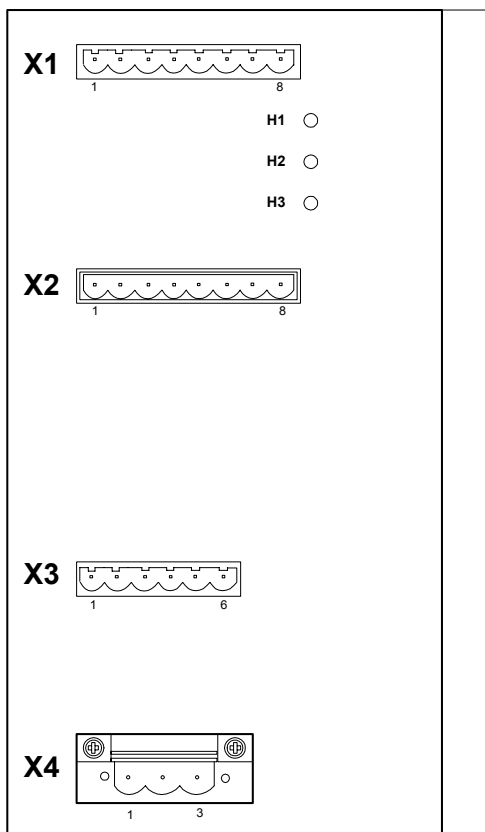

<b>X1</b>	Pin No.		
	1 - 2	Stepper Motor A+	
	3 - 4	Stepper Motor A-	
	5 - 6	Stepper Motor B+	
	7 - 8	Stepper Motor B-	
<b>X2</b>	Pin No.		
	1	External Supply	0V
	2	External Supply	+24V
	3	DISABLE Input	(EXT 2)
	4	START Input	(EXT 1)
	5	PRIME Input	
	6	FlexNet	DATA
	7	FlexNet	GND
	8	FlexNet	/DATA
<b>X3</b>	Pin No.		
	1	Mains Supply	OK +24V Out
	2	BUSY 3	PNP Output +24V / max. 300 mA
	3	BUSY 2	PNP Output +24V / max. 300 mA
	4	BUSY 1	NPN Output 0V / max. 300 mA
	5	SAFETY Sensor	Output +24V / max. 200 mA
	6	SAFETY Sensor	Input +24V
<b>X4</b>	Pin No.		
	1	Mains Supply	FASE
	2	Mains Supply	EARTH
	3	Mains Supply	ZERO

### LED Indicators

H1	+24V Power to Pump Controller
H2	Communication to Master Controller
H3	BUSY 3 Indicator

Fig. 5-1

### 5.1 Stepper Motor Connector – X1

The stepper motor is connected to X1 by an 4 or 8 wire straight cable.

If the cable mounted on stepper motor is too short, an extra cable according to drawings below must be used.

Note that cable with screen must be used.

Mounting of 4 wire straight cable.

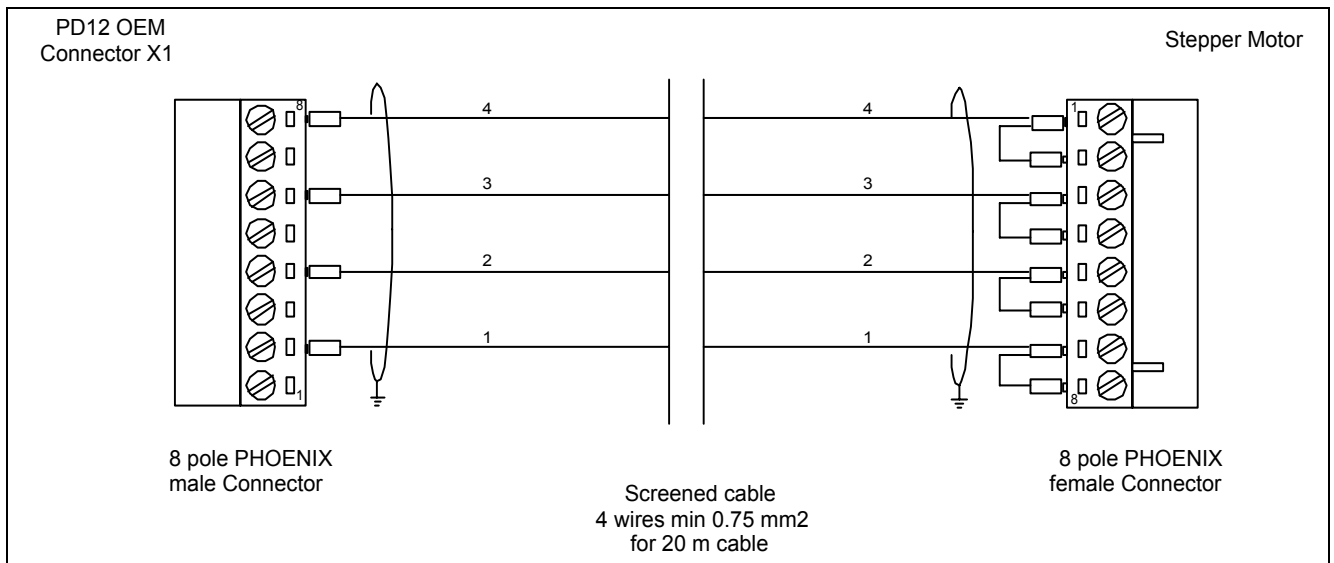

**Fig. 5-2**

Mounting of 8 wire straight cable.

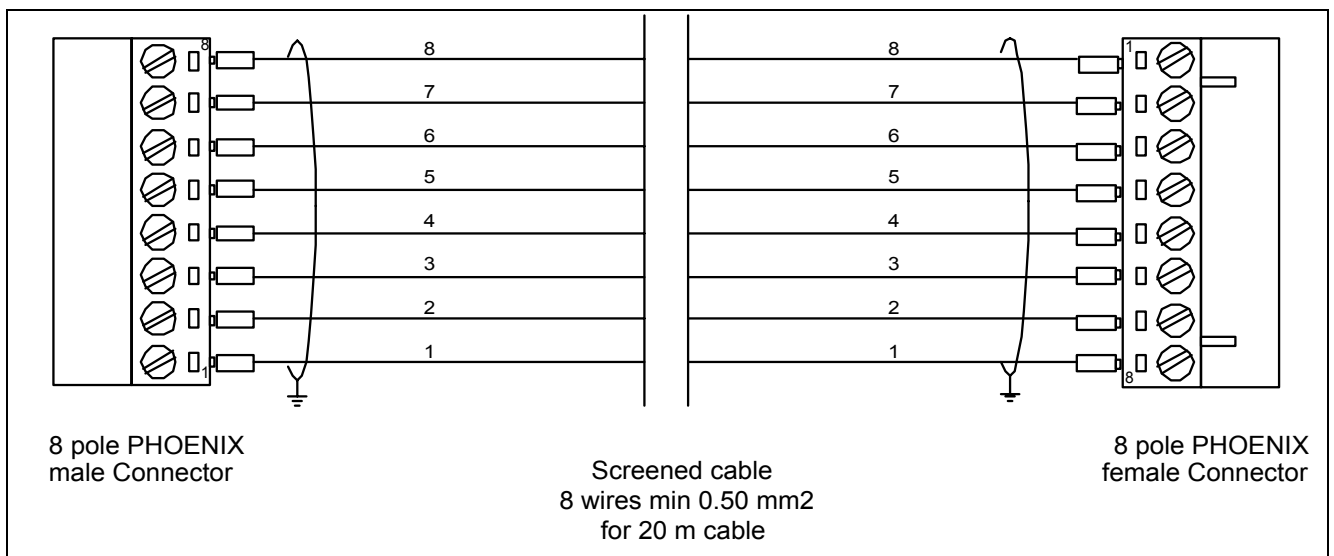

**Fig. 5-3**

## 5.2 Inputs Connector – X2

Pin 1            External Supply 0V  
Pin 2            External Supply +24V

The external DC supply for Controller PCB 20-214-005 is normally supplied by the controlling equipment, for example the main power supply from the machine, the PD12 OEM is mounted in. This supply makes it possible to turn OFF the Mains Supply connected to X4, when for example an emergency stop requires to power to be removed from the stepper motor and still have the Master Controller (MC12) communicating with pump controller, so avoiding a restart of the filling system.

Pin 3	DISABLE input	This Input can be used for disabling the pump from reacting on a START signal on Pin 4 or used for special functions  +24V / max. 5 mA load.
Pin 4	START input	This Input is used for START signal to the pump to make a dispense.  +24V / max. 5 mA load.
Pin 5	PRIME input	This Input is used for PRIMING (Purging), the pump will run with approx. 125 rpm when applying +24V on this pin, stops when the +24V is removed  +24V / max. 10 mA load.
Pin 6	FlexNet	RS485 Connection            DATA
Pin 7	FlexNet	RS485 Connection            GND
Pin 8	FlexNet	RS485 Connection            Inverted DATA

The FlexNet is used for serial communication between the PD12 OEM and the Master Controller (MC12). The cable can be twisted pair or screened with a max. Length of 300 feet (100 m).

All Inputs can be wired in parallel, so a double terminal connector is used for X3 to ease these connections.

	<b>PD12 OEM Installation Manual</b>		
	<b>Re.: Installation</b>	<b>Rev.: 1.03</b>	<b>Date: 2008-05-30</b>

### 5.3 *Outputs Connector – X3*

Pin 1            Mains supply Indicator output                            +24V max. 300 mA load.

This output is used to monitor the mains internal fuse and mains supply for the pump controller.

Pin 2–4            Status Outputs  
These outputs are all active, when the pump is priming, dispensing or pumping.

Pin 2            BUSY 3            PNP Output    +24V max. 300 mA load.

This output is active when the Controller PCB is active and the Stepper Motor Controller is sending step-pulses to X1. (This output is checking the Fuse on 20-312-002). This output does NOT include the functionality from Timer 18 and Timer 19 (see MC12 Manual).

Pin 3            BUSY 2            PNP Output    +24V max. 300 mA load.

This output is active when the Controller PCB is active and includes the functionality from Timer 18 and Timer 19 (see MC12 Manual)

Pin 4            BUSY 1            NPN Output    OC to 0V max. 100 mA load.

This output is active when the Controller PCB is active and includes the functionality from Timer 18 and Timer 19 (see MC12 Manual)

Pin 5            Tube-bridge sensor output                            +24V max. 200 mA load.

Pin 6            Tube-bridge sensor input                            +24V max. 5 mA load.

The tube-bridge sensor input is normally used to inhibit the pump from starting priming, dispensing or pumping, when the tube-bridge is not mounted. If the +24V is remove during either priming, dispensing or pumping, the pump will stop immediately.

The MC12 has information of the status of the tube-bridge sensor input.

### 5.4 *X4 Mains supply connector*

Pin 1            Mains supply FASE

Pin 2            Mains supply EARTH

Pin 3            Mains supply ZERO

### 5.5 Addressing of filling station

Address	1	2	3	4	5	6	7	8	9	10	11	12	13	14	15	16
SW1	1	0	1	0	1	0	1	0	1	0	0	1	0	1	1	0
SW2	1	1	0	0	1	1	0	0	1	1	0	1	1	0	0	0
SW3	1	1	1	1	0	0	0	0	1	1	1	0	0	0	0	0
SW4	1	1	1	1	1	1	1	1	0	0	0	0	0	0	0	0

Fig. 5-4

Address "1" is the factory setting of PD12.

If the PD12 is one of several filling stations in a system, none of the stations may have the same address and it must therefore be changed.

Change of address is performed via a dip-switch placed at the bottom of the PD12. This change may only be carried out when the machine is turned off at the main isolator.

Addresses between 1 and 16 may be chosen, and Fig. 5-4 shows the various combinations.

### 5.6 Connection to NET connector on Master Controller MC12

The PD12 OEM control unit must be connected to NET connector on Master Controller MC12 by use of a 4-pin DIN connector (supplied with MC12).

The NET connector on MC12 has following pin configuration.

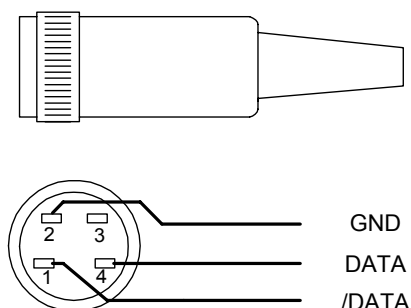

Fig. 5-5

Pin 1	/DATA	Connect to X2.8
Pin 2	GND	Connect to X2.7
Pin 3	Not used	NA
Pin 4	DATA	Connect to X2.6

## 6 Selection of internal or external supply for Controller PCB

During manufacture of the PD12 OEM, external 24 VDC supply for Controller PCB is chosen, but internal 24 VDC supply of Controller PCB can be chosen.

Note that if internal supply is chosen, restart of MC12 will be necessary in the event of missing or disabled power supply of PD12 OEM.



Fig. 6-1

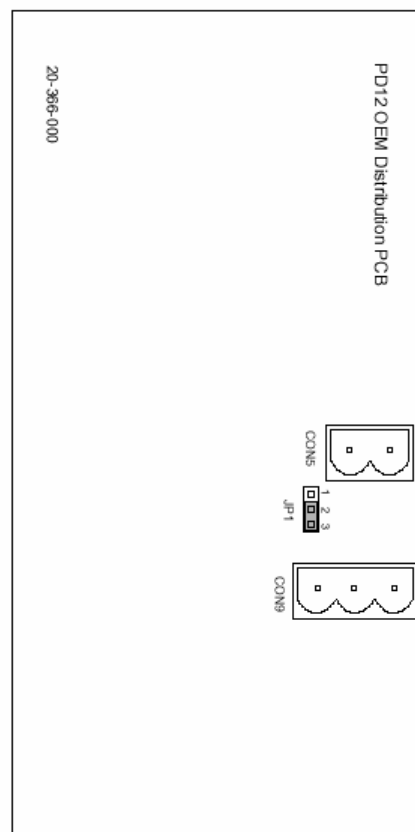

Fig. 6-2

On the distribution PCB the Jumper JP1 (located between CON5 and CON9) is used to select the 24VDC supply for the Controller PCB 20-214-005.

Position	Description
1-2	Internal 24VDC supply
2-3	External 24VDC supply on X2 (default)

## 7 Change of voltage

### 7.1 Change of voltage

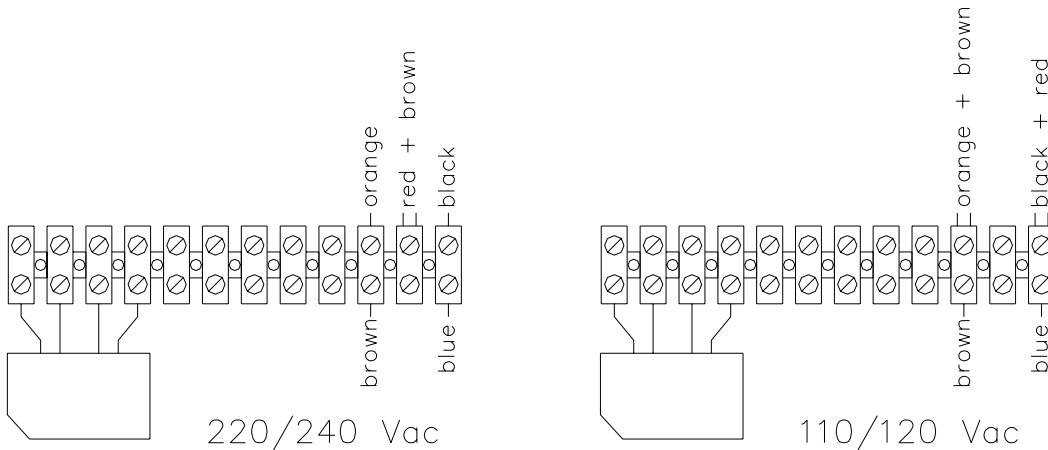

**Fig. 7.1**

The PD12 can be converted to accept another supply voltage.

The conversion can be made inside the machine by moving the cables of the transformer clamps.

## 8 Copyright

Copyright (c) 2008 Watson-Marlow Flexicon. All rights to this manual belong to Watson-Marlow Flexicon. Neither the complete manual nor parts of it may be translated, copied, printed or published in any form or by any means without permission in writing from Watson-Marlow Flexicon.

Watson-Marlow Flexicon is convinced that the information of this manual is correct, but Watson-Marlow Flexicon cannot be held responsible for it.

Watson-Marlow Flexicon reserves the right to update and amend this manual without previous notice. Watson-Marlow Flexicon is under no obligation to update manuals already published.