

# MC100

## PUMP CONTROL MODULE



MC100 is a pump control module capable of controlling up to 16 Watson-Marlow Flexicon Pumps. The basic function is to receive filling data (recipes) from a filling line control system through an industrial fieldbus, and to calculate operating values for the pumps and receive/transmit those through a FlexNet protocol.

MC100 constitutes with Watson-Marlow Flexicon Pumps a filling system that is designed for incorporation into a filling line as described below.

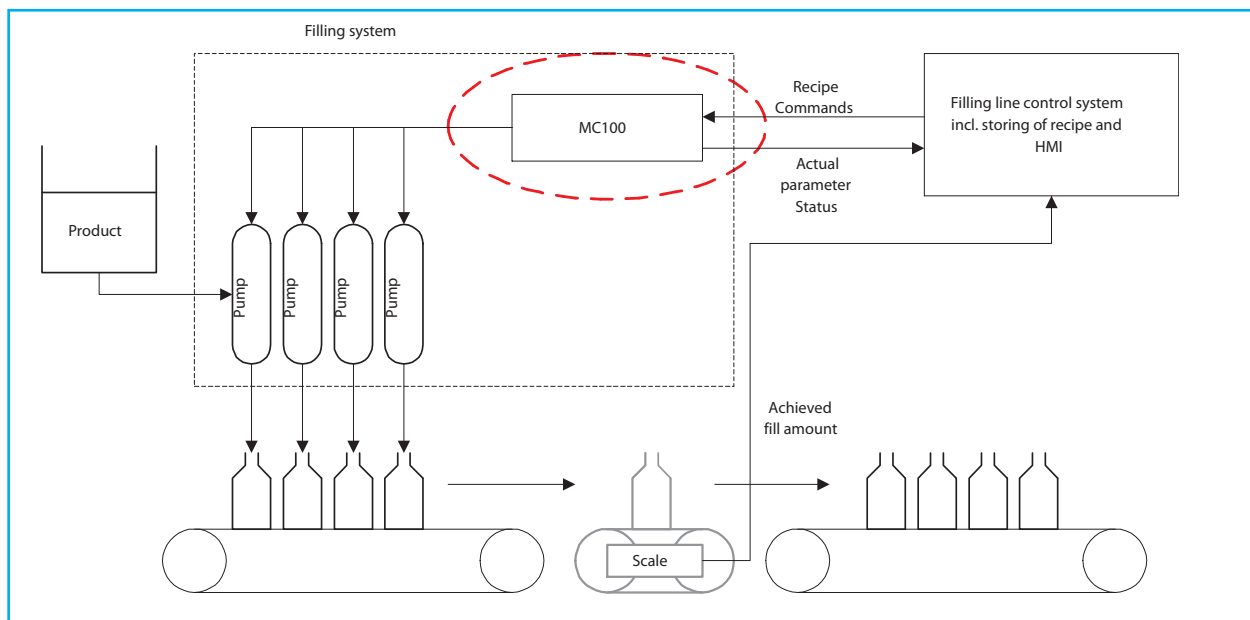

## Watson-Marlow Flexicon

Frejasvej 2-6  
DK-4100 Ringsted  
Denmark  
Tel. +45 57 67 11 55  
Fax. +45 57 67 05 41  
flexicon@flexicon.dk  
www.wmflexicon.dk



# MC100 TECHNICAL SPECIFICATIONS

MC100 is physically a small module intended for mounting inside the control cabinet of the filling line.

As MC100 is designed with the purpose of incorporating a Watson-Marlow Flexicon filling system into a filling Line, MC100 has no operator interface. Therefore, an operator cannot start or stop the connected pumps, nor set the recipes or display actual parameters on a MC100.

Recipes, containing specifications, such as filling volume and filling speed for the requested filling, are sent to MC100 via the fieldbus communication. Based on the recipes and pump/tube properties, MC100 will calculate operating values for the pumps in the filling system.

During the production achieved fill weight is sent to the MC100 by the filling line control system, and MC100 will recalculate the operating values for the pumps.

Operating values will be sent to the pumps via the FlexNet communication protocol.

The actual parameters used to calculate the operating values for the pumps are available through fieldbus for cross reference with recipes.

Start commands for the individual pump are sent via fieldbus to MC100 which will convey the start command to the pump. Status signals, warnings and alarms from each pump or MC100 are available for the filling line control system via fieldbus.

Note that depending on pump type, start and status signals can be sent to/received directly from the individual pump by 24V signals.

MC100 holds no recipes or historical data. Only data for current setup of filling system is stored internally.

### Fieldbus communication with filling line control system:

DeviceNet

### Pumps:

Max 16 pumps can be connected and controlled

Pumps must communicate with MC100 via FlexNet protocol

Available pumps: PD12, PD22 and GD30

Software that must be installed in pumps:

- PD12: PD12B DS V1.8
- PD22: PD22 DS V1.8
- GD30: GD30 DS V3.4

### Material and surface treatment:

Mounting box made from aluminium

All aluminium parts anodised (conductive)

### Environmental:

Ingress protection according to IP30

NEMA 1 enclosure

Surrounding temperature 10 – 40°C

### Mounting:

MC100 to be mounted on DIN rail size 35

### Power supply:

- Supply 24 VDC +/- 10 %
- Power consumption less than 15 VA
- Slow Blow Fuse max. 1A

### Weight:

0,5 kg

### Dimensions in mm/inch

