

OPERATOR'S MANUAL
FLEXIBLE FEEDING SYSTEM

FF20

TABLE OF CONTENTS:

1.	DECLARATION OF CONFORMITY.....	3
2.	CAUTION	4
3.	GENERAL INFORMATION.....	5
3.1.	Unpacking and inspection.....	5
4.	INSTALLATION.....	6
4.1.	Assembly of FlexFeed 20.....	6
4.2.	Installation of compressed air.....	7
4.3.	Electric installation.....	8
4.4.	Control panel.....	8
5.	OPERATION.....	9
5.1.	Bottle adjustment.....	9
5.1.1.	Adjusting the outlet sluice.....	9
5.1.2.	Adjusting the inlet sluice.....	10
5.1.3.	Adjusting the bottle pusher.....	11
5.1.4.	Adjusting the inlet sensor.....	11
5.1.5.	Adjusting the rotary table bottle guide.....	13
5.2.	Preparing filling series.....	14
5.3.	Before starting production:.....	15
5.3.1.	Starting production.....	15
5.3.2.	Pausing or stopping production.....	15
6.	CLEANING.....	16
6.1.	Cleaning of the frame.....	16
7.	MAINTENANCE.....	17
7.1.	Disposal:.....	17
8.	INTERFACE.....	17
8.1.1.	“FlexFeed”.....	17
8.1.2.	“Filler”.....	17
9.	CHANGE OF POWER.....	18
10.	TECHNICAL SPECIFICATIONS.....	19
11.	CONNECTING DUMPING NOZZLE.....	20
12.	TYPICAL INSTALLATION.....	21
13.	AIR SERVICE PARTS.....	22
14.	ANNEX A.....	23
15.	ANNEX B.....	23
16.	COPYRIGHT.....	23

1. DECLARATION OF CONFORMITY.

We Flexicon A/S
Frejasvej 2-6
DK-4100 Ringsted

declare on our sole responsibility that the product:

FF20 – FlexFeed module



to which this declaration relates is in conformity with the following standard(s):

EN 292: Safety of Machinery: Basic Concepts,
General Principles of design.

according to the provisions in the Directives:

98/37/EEC, 91/368/EEC and 93/44/EEC: Machine-directive.
73/023: Low Voltage-directive.

EMC 89/336/EEC

 Flexicon a/s [®] <small>Denmark</small>	
Model	FF20
Serial No.	YYWW 1234
Supply	230V/50Hz/50W
Year	2001
	

Ringsted March 2007

Mads Ulric Jensen
Signature.

2. CAUTION

This manual should be read before using the FlexFeed 20.

Explanations to the pictograms:

"Warning against touching"/"Warning against dangerous part of the machine":



Warning against high voltage:



The mains switch and pneumatic emergency stop (E in fig. 1) is used for emergency stopping.

The cover (S in Fig. 1) should be mounted when operating the FlexFeed 20.

The FlexFeed 20 should not be connected to power or compressed air supply when it is installed or adjusted.

The FlexFeed 20 must be placed on a stable bed plate and in such a way, that it is not exposed to great humidity, high temperatures or other abnormal operating-environments. It is not to be used in explosion hazardous environments.

It is prohibited to maintain or clean the FlexFeed 20, when it is connected to the power supply.

It is prohibited for unauthorised personnel to open the cover of the FlexFeed 20's electrical parts (the control box).

Always remember that the FlexFeed 20 must be earthed by way of the switch.

Handle the filling needles with caution.

3. GENERAL INFORMATION.

3.1. Unpacking and inspection.

FlexFeed 20 is a rotary bottle handling system.

Together with a PD12I/PF6 and a MC12 the units will make up a fully automatic filling system.

Please check that you have received the ordered goods and that they are not damaged during transport. If so, please contact Flexicon or your supplier.

If you should require any spare parts or accessories in the future, please state serial number when giving your order.

The serial number is stamped on a label located on the back of the machine.

Please be aware that this machine must always be grounded via the power supply.

4. INSTALLATION.

4.1. Assembly of FlexFeed 20.

During transportation the FlexFeed 20, the inlet and outlet trays and the filling stand are dismantled and must therefore be re-attached to the FlexFeed 20 frame.

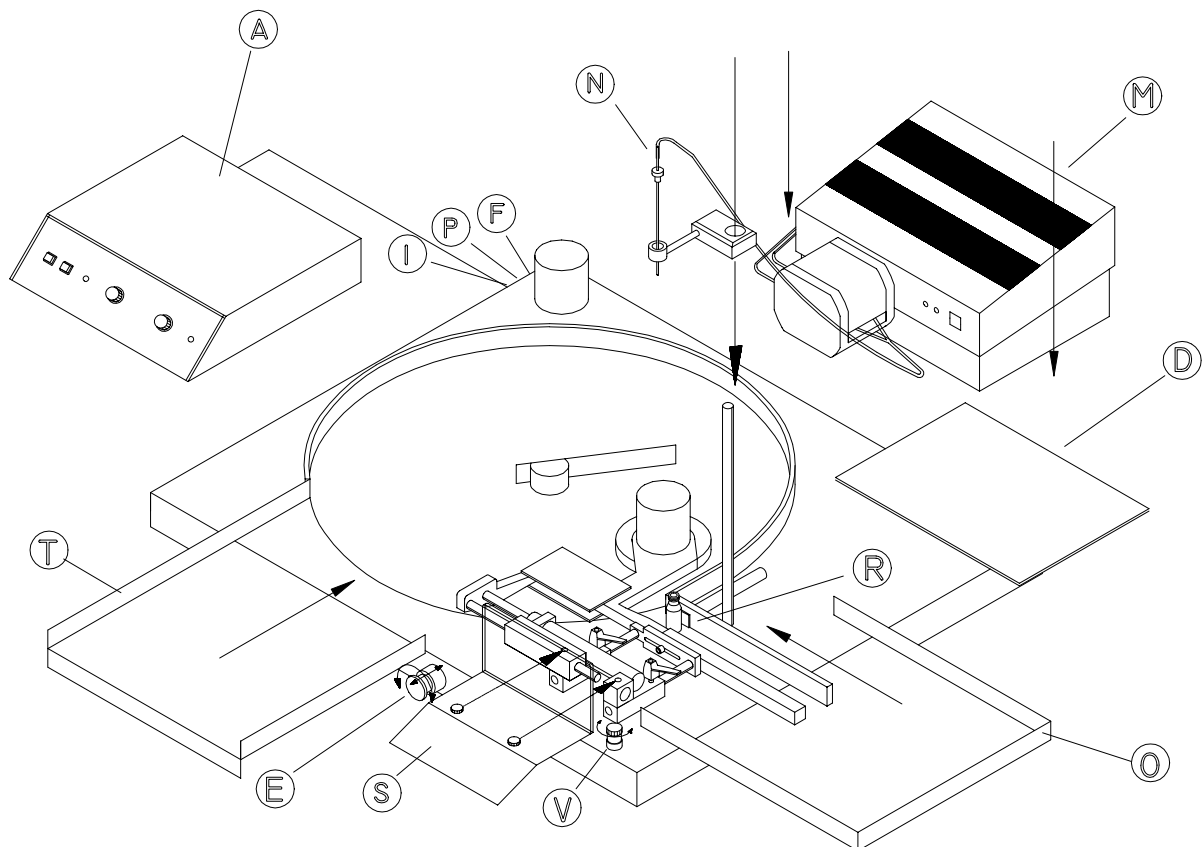

Fig. 1

Remove the cover plate (S) Fig. 1 via the two black finger screws.

Attach the inlet tray (T) Fig. 1 by Allen screws in the four holes in the frame.

Attach the outlet tray (O) Fig. 1 by Allen screws in the four holes in the frame.

Put the cover plate back in place.

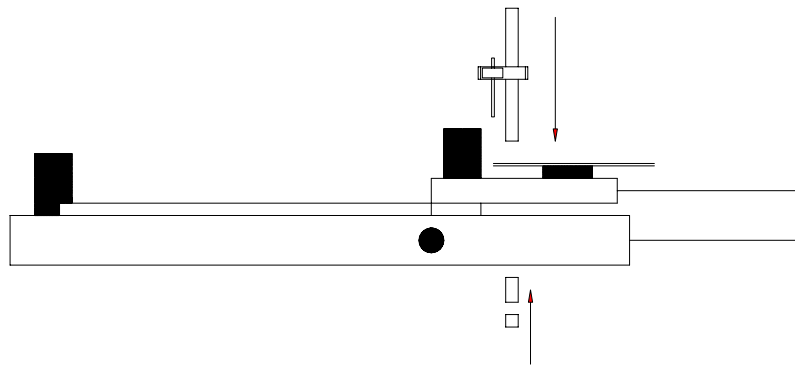

Fig. 2

Attach the filling stand Fig. 2 to the large hole in the frame cover plate. The spacing bush must be positioned between the cover plate and the cheek, and the nut fixes the stand.

4.2. Installation of compressed air.

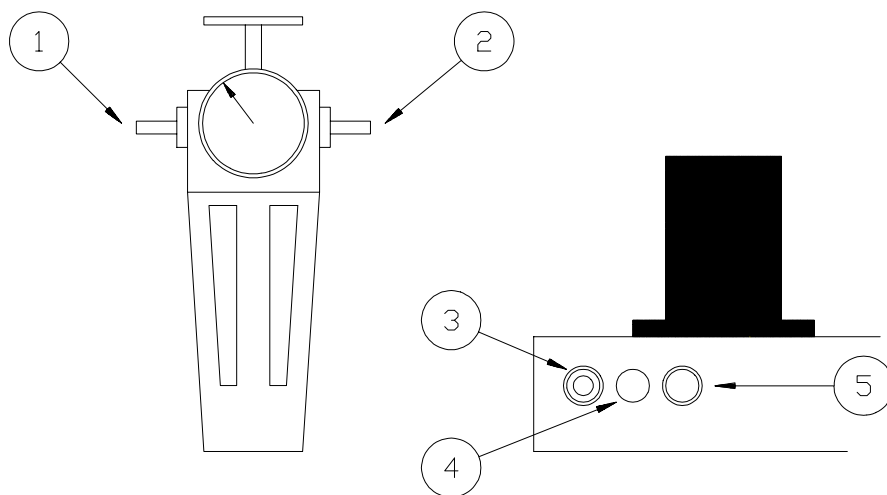

Fig. 3

Compressed air (5 - 7 bar) is connected to the pressure regulator inlet (1) Fig. 3 The outlet (2) is available for the input on FlexFeed 20 (3).

All exhaust air from FlexFeed 20 is gathered and released via the filter (4) which can be replaced by the supplied hose connection, so that all exhaust air can be expelled from the room.

If using a dumping needle, the air supply for this can be taken from the outlet (D) in fig. 1.

4.3. Electric installation.

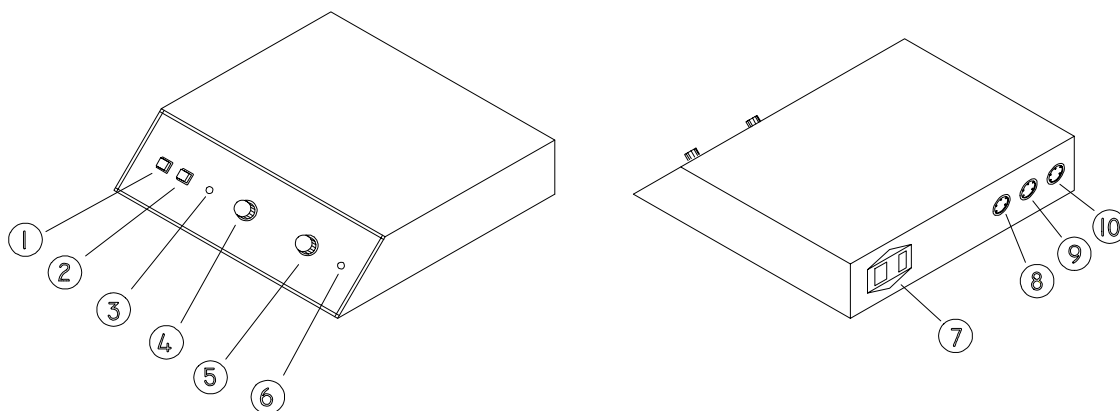

Fig. 4

The 12-pin cable marked 4 is connected to FlexFeed 20 Fig.3 (5) and to the control panel (8) FlexFeed.

The cable marked 2, connects FlexFeed 20 and the MC12 (external GO) or PD12I (external 1) in use via the **Filler** socket (10)

The main cable is connected to the socket (7) and FlexFeed 20 is now ready to be adjusted to the required bottle.

4.4. Control panel.

1. **Mode**, switches between manual and automatic operation.
2. **Release**, carries out bottle exchange during manual operation.
3. **Sensor**, bottle sensor control lamp.
4. **Off delay**, variable timer for bottle exchange delays.
5. **Speed**, controls the speed of the rotary table. Total CCW, stop the rotary table.
6. **Power**, power control lamp.

During start-up of FlexFeed 20 the **mode** switch must be in the **manual** position.

5. OPERATION.

5.1. Bottle adjustment.

5.1.1. Adjusting the outlet sluice

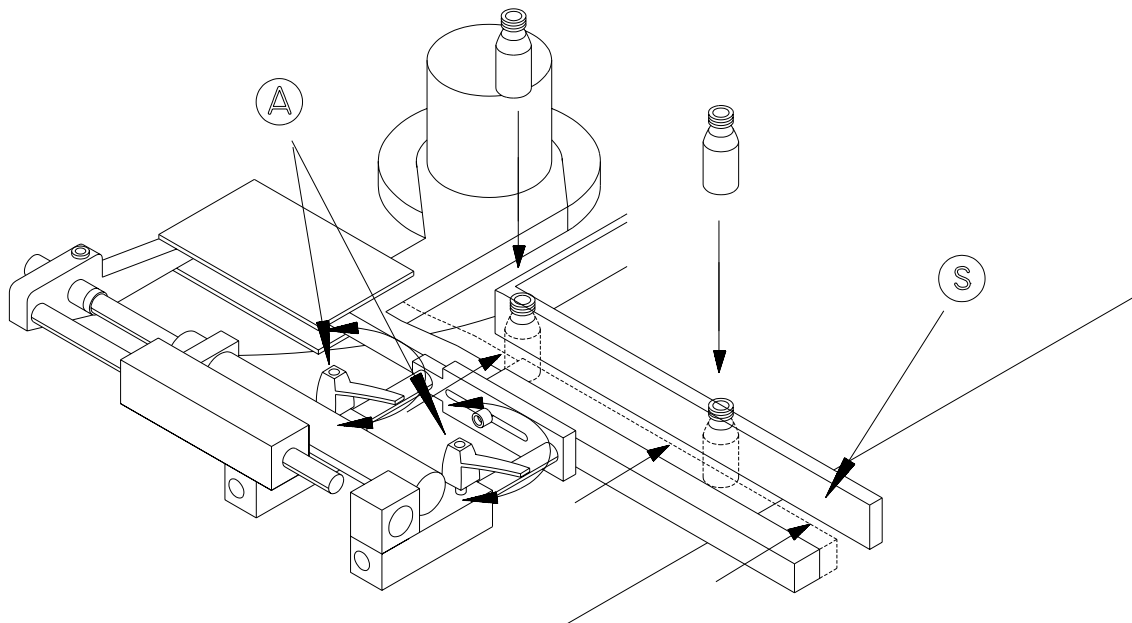

Fig. 5

Press the pneumatic emergency stop and the pressure is released from the system.

Loosen the two wing screws (A) so that the guide rail can be pushed forward and backward.

Place two bottles at each end of the longitudinal bottle sluice and adjust the guide rail at a distance of about 1 mm to the bottles. Tighten the wing screws (A)

Check that all bottles run freely in the bottle sluice.

Note: when running with soft plastic bottles it is better if the distance is smaller so the bottles move a little tight.

5.1.2. Adjusting the inlet sluice

Fig. 8

Loosen the Allen screw (B) so that the guide rail can be adjusted in the other direction.

Place two bottles at each end of the bottle sluice and adjust the guide rail at a distance of about 1 mm to the bottles. Tighten the Allen screw (A) Fig. 8
Check that all bottles run freely in the bottle inlet sluice.

5.1.3. Adjusting the bottle pusher

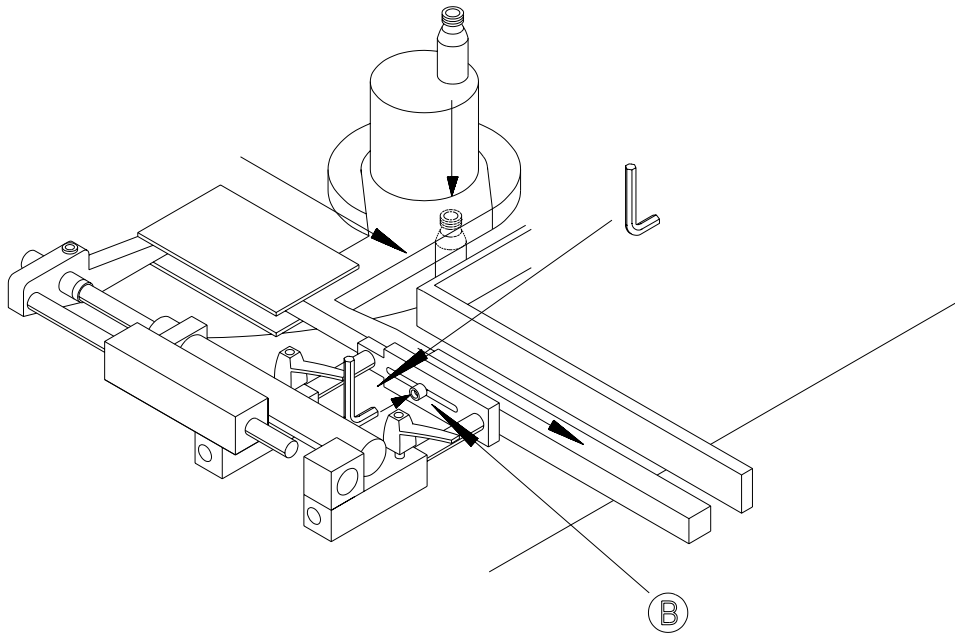
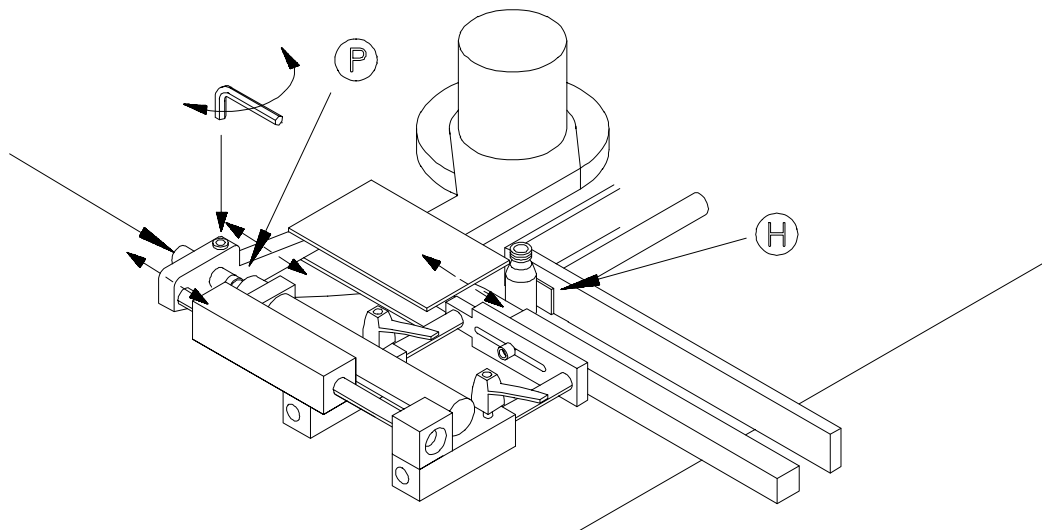

Fig. 8

Place a bottle in the filling positioning piece (H) and loosen the Allen screw on the bottle feeder (P). Push the bottle feeder piston rod all the way in and adjust the bottle feeder so that it is at a distance of about 1 mm from the bottle in the filling area (H). An external throttle valve (V in fig. 1) controls the speed of bottle feeder (P).

5.1.4. Adjusting the inlet sensor

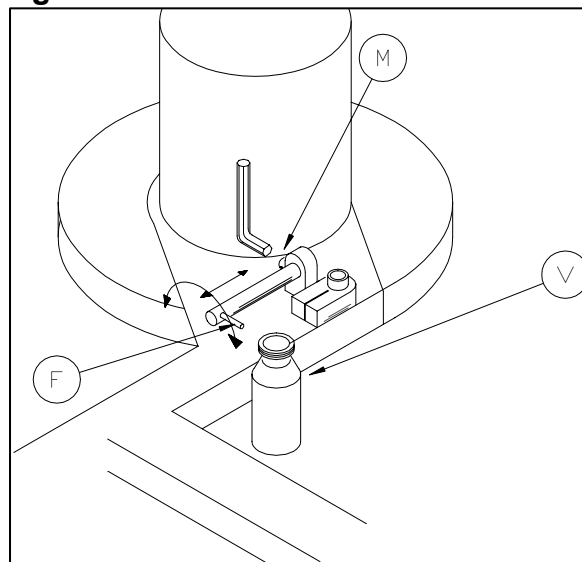

Fig. 9

Push the bottle feeder all the way to the left and place a bottle in the waiting position (V). Loosen the Allen Screw (M) and adjust the sensor (F) in order to enable it to detect the waiting bottle (look at the control lamp on the front plate of the control panel).

Tighten the Allen screw.

Put the cover plate back in place, make sure the bottle feeder is still all the way to left and then reactivate the compressed air by releasing the emergency stop (E in Fig. 1).

NOTE: WHEN OPERATING WITH SMALL VIALS.

Small vials can due to their small size be pushed away from the waiting gate by the queuing vials. When this happens the sensor no longer detects the vial. Therefore the FF20 will wait for the next vial to be ready in the gate. When this next vial is pushed into the filling position, the previous vial will be pushed in front of it and will not be filled correctly. To prevent this, the sensor should be adjusted so it can still detect the vials when they are moved up to 1 cm away from the waiting position.

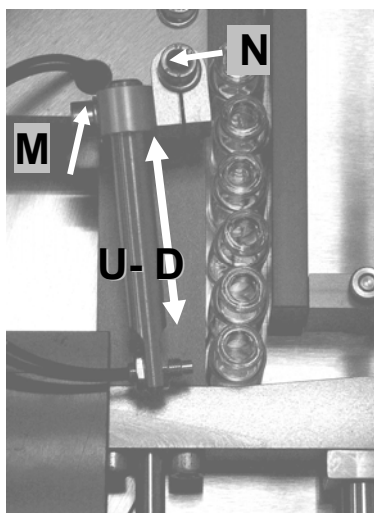

Loosen Allen screw (M) and adjust sensor in direction U-D.

Move the vial from the waiting position circa 1 cm to the right.

Loosen Allen screw (N)
Adjust the sensor in the I – O direction until the control lamp light up again.

Tighten both Allen screws.

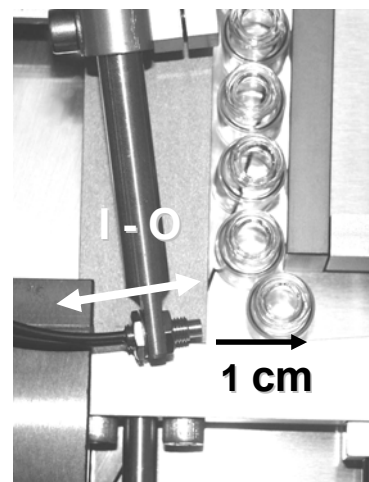

5.1.5. Adjusting the rotary table bottle guide

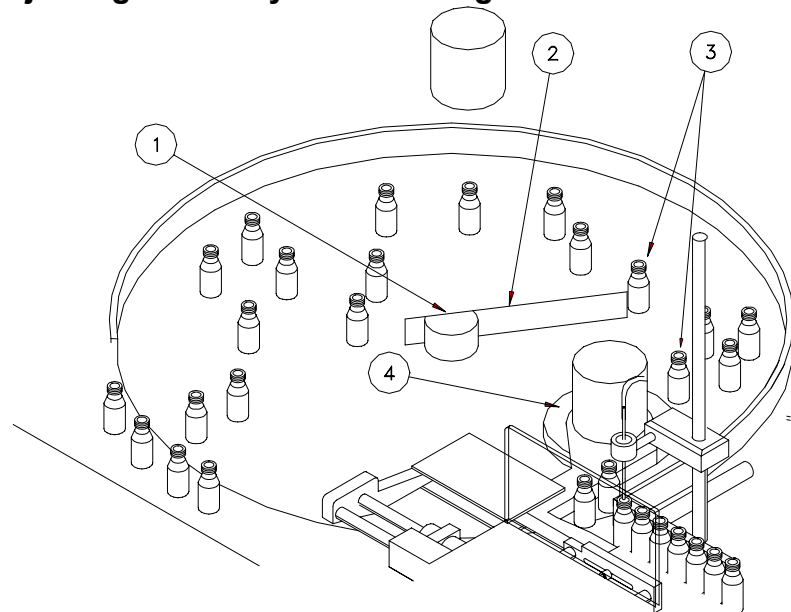

Fig. 10

Loosen the Allen screw (1) and adjust the bottle guide (2) to the greatest possible distance to the outer guide rail. The greatest distance is found by letting a bottle run along the bottle guide Fig. (2) When it reaches the picking wheel (Fig. 4) the bottle must enter the bottle sluice.

Place some bottles on the rotary table, and each time the release button is pressed, the system will exchange a bottle. Carry out a number of exchanges in order to check the adjustment.

FlexFeed 20 has now been adjusted to the required bottle.

Finally the filling needle must be positioned and adjusted over the bottle in the filling station, and the filler can then be programmed.

5.2. Preparing filling series.

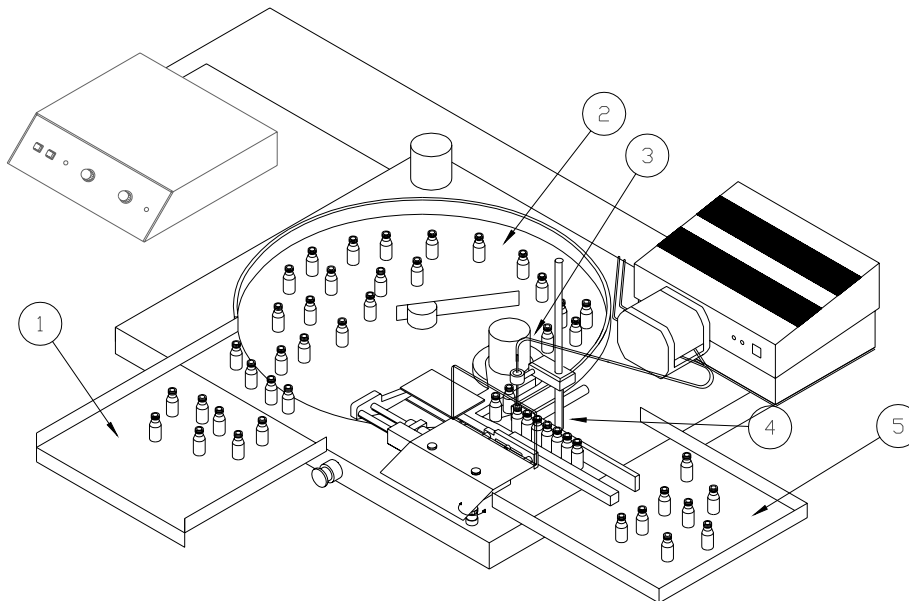

Fig. 11

When the filling machine has been programmed and FlexFeed 20 adjusted to the required bottle size, a number of bottles are placed on the inlet tray (1).

The bottles are pushed into the rotary table (2) after which they will go to the edge of the rotary table automatically and enter the bottle sluice (3). The bottles which the bottle sluice could not take are taken in turn again till they have all passed through the sluice.

5.3. Before starting production:

Switch off all components.

5.3.1. Starting production

1. Connect and turn on compressed air
2. Switch on power to FF20, Pump(s) and finally MC12.

It is important to that compressed air is turned on before the FF20 is activated.

The filling series starts when the **mode** switch is in the **automatic** position. When the sensor detects a bottle, this will go to the filling area (4) Fig.11 and the filling machine will start.

After a filling the FlexFeed 20 will deliver the next bottle into the filling position. The now filled bottle is pushed through the sluice and will end in the outlet tray Fig. 11.5.

The tray is replaceable and can therefore be taken out of its guides, and a new one can be inserted ready for filling. Replacement trays can be supplied.

5.3.2. Pausing or stopping production

If the filling has to be stopped during a series (due to replacement of a tray) the **mode** switch can be set at **manual**.

To continue the series, set the switch to **automatic**.

! DO NOT USE THE EMERGENCY STOP TO PAUSE AND RESTART PRODUCTION. !

6. CLEANING.

6.1. Cleaning of the frame.

The FlexFeed 20 frame is not connected to the mains (110/220 VAC), and it is therefore quite safe to use water or a similar liquid for the cleaning of the frame. If the rotary table must be removed in order to be cleaned, this can be done as follows:

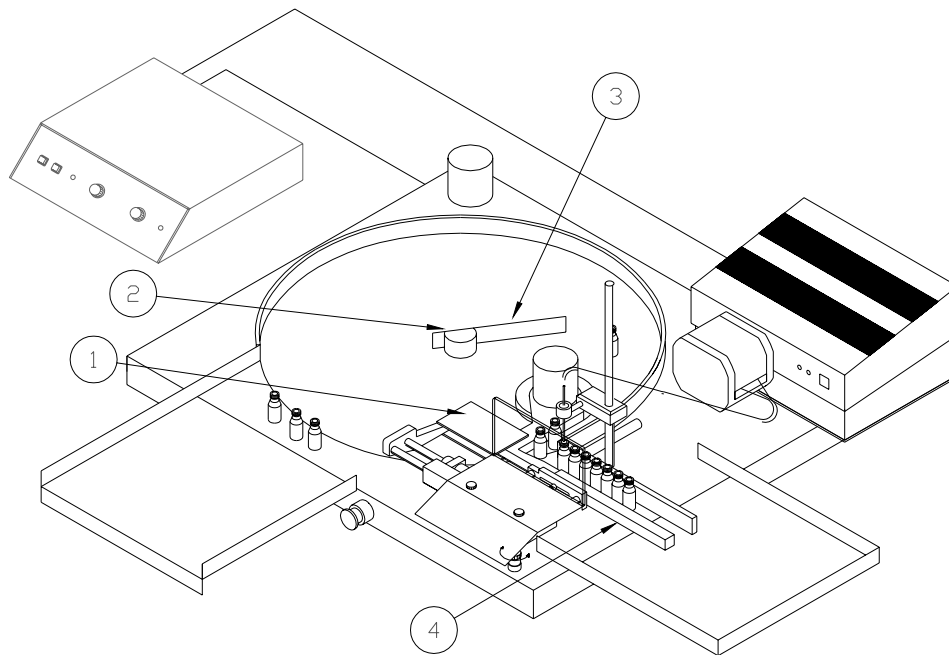

Fig. 12

Remove the cover plate over the bottle exchanger.

Loosen the Allen screw and remove the bottle feeder (1)

Loosen the Allen screw (2) and lift the bottle guide (3) off.

Remove the Allen screw for the guide rail adjustment (4) and the guide rail with the picking wheel can be put to one side.

The rotary table can be removed and cleaned.

7. MAINTENANCE.

All slide-bearing bushings and bearings are sealed and are therefore maintenance-free.

The transmission belt for the rotary table can be tightened by dismantling the cover over the motor. Loosen the four small Allen screws holding the motor, and turn it until the belt has been correctly tightened.

7.1. Disposal:

The machines can be disposed in the same way as Personal Computers.

8. INTERFACE.

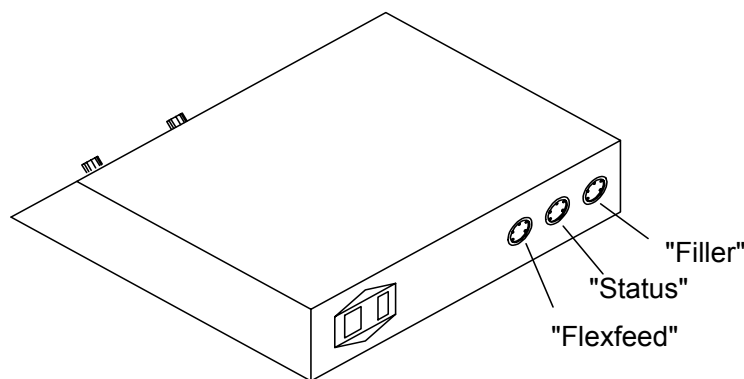

Fig. 13

8.1.1. "FlexFeed"

Multi cable connecting the control panel to the frame.

"Status"

- Pin 1: Input for disabling of bottle exchange.
+ 5-50 VDC. Activating this pin will disable the bottle exchange.
- Pin 2: +24 VDC, max. 250 mA.
- Pin 3: Ground
- Pin 4: Status output, +24 VDC max. 100 mA.
Pin 3 is grounded via an open collector during the bottle exchange.
- Pin 5: No connection.

8.1.2. "Filler"

- Pin 1: Input for start of bottle exchange.
Pin 1 is internally fitted with a pull-up resistor, and the input must be grounded as long as the filling is being carried out.
- Pin 2: Ground.
- Pin 3: Output for start of filler.
+24 VDC, max. 5 mA start signal, which is kept HIGH till the start of the filler has been detected.

9. CHANGE OF POWER.

FlexFeed 20 can be switched between 240 and 120 volts power supply.

The change-over is carried out inside the control box by moving the wires of the screw terminals located on the transformer.

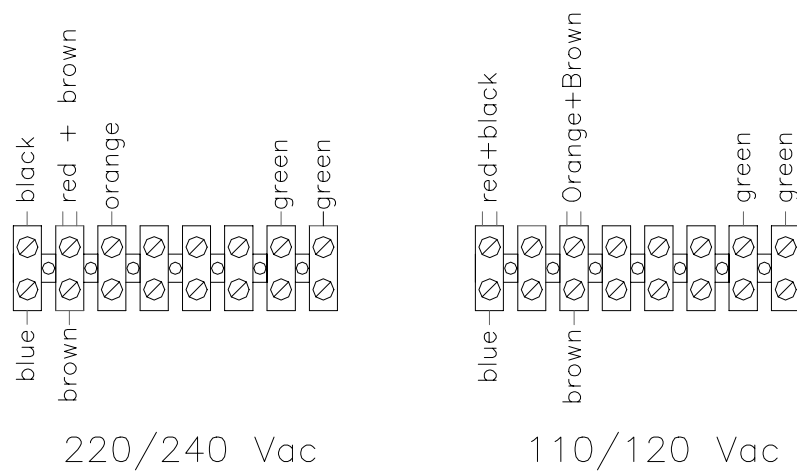

Fig. 14

10. TECHNICAL SPECIFICATIONS.

Main supply : 110/240 VAC 50/60 Hz. grounded.

Power consumption : Max. 100 W.

Pneumatic pressure : 5 - 7 bar.

Air consumption : Max. 3 litre / min.

Bottle size : A diameter of about 12 - 50 mm.

Weight : 40 kg.

FRAME

Materials : AISI304 steel, anodized aluminium, Delrin.

Ingress protection : IP54

CABINET

Materials : Anodized aluminium.

Ingress protection : IP31

Interface : 1 input (5-50 VDC) for disable.

1 output (24 V/100 mA) for status

In- and outputs have ground as reference.

in- and outputs for interface to filling machine.

Order No. : 91-150-000

Manufactured by : Flexicon A/S
Frejasvej 2-6
DK-4100 Ringsted
Denmark

11. CONNECTING DUMPING NOZZLE

If using a dumping needle with FlexFeed 20 is desired, the stainless steel off-line control box can be supplied in order to make the necessary connections.

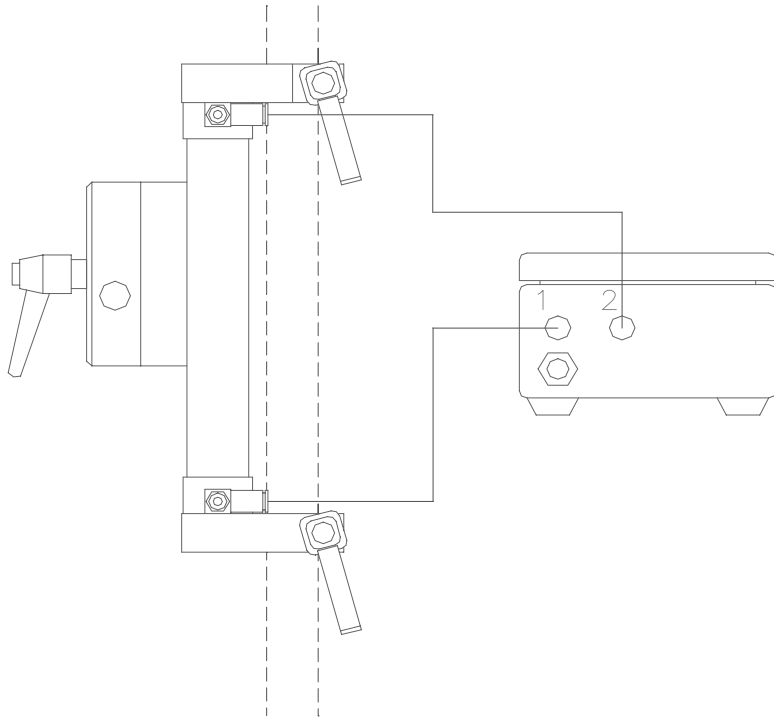

Fig. 15

The air supply for the control box can be reached from the nozzle placed on FF20. Please see figure 1 (D).

12. TYPICAL INSTALLATION

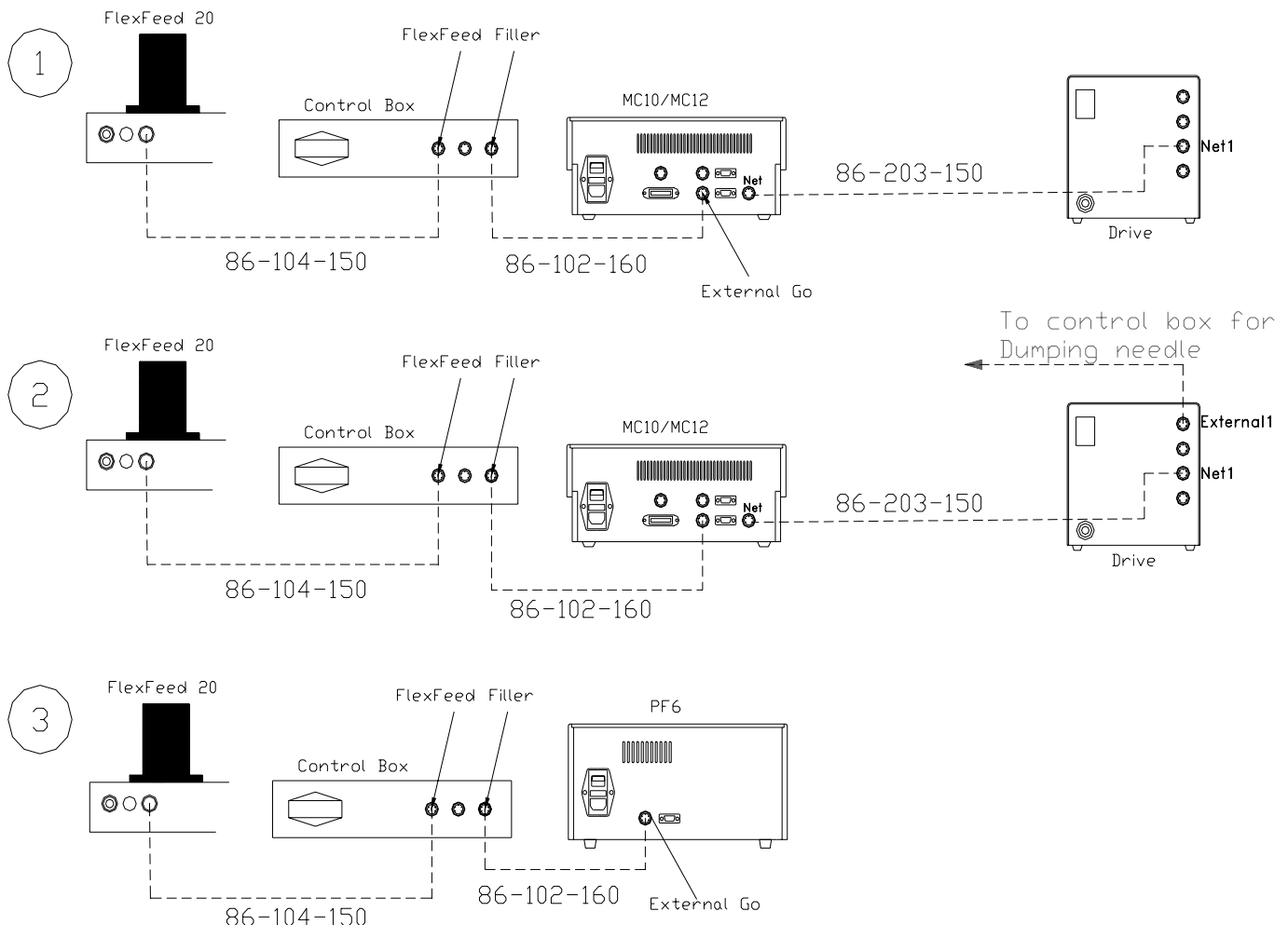

Fig. 16

The above shown are the configurations for FlexFeed 20 connected to a pump and a controller (MC12/PF6).

Flexicon however recommends the installation nr. 1.

The number placed at the corresponding cable is the part no.

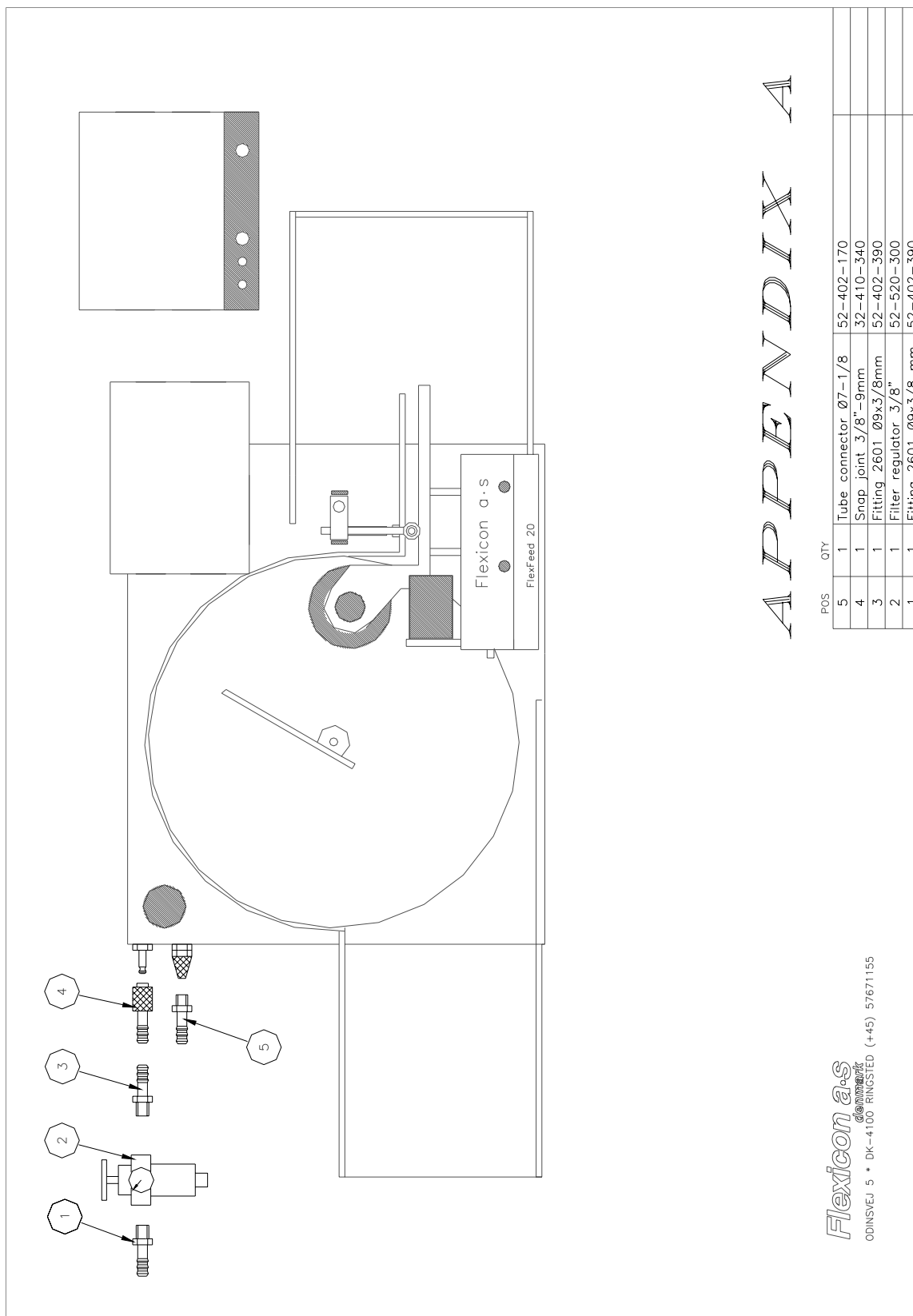

This should be stated when ordering.

13. AIR SERVICE PARTS



APPENDIX A

Flexicon a.s.
 ODINSVEJ 5 • DK-4100 RINGSTED (+45) 57671155

	
Model	FF20
Serial No.	yyww 1234
Supply	230V/50Hz/50W
Year	2006
	

14. ANNEX A

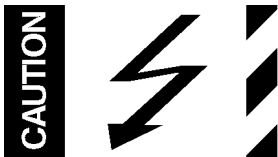

15. ANNEX B

Sound pressure level: $L_{Aeq} < 70$ dB(a)

16. COPYRIGHT

COPYRIGHT

COPYRIGHT (C) 2005 FLEXICON A/S. All rights are reserved. No part of this publication may be reproduced, transmitted, transcribed, stored in a retrieval system or translated into any form or by any means, whether it be manual or by any technical aid, without the prior written consent of Flexicon A/S, Ringsted, Denmark.

Flexicon A/S believes that the information contained in the manual is correct, but does not assume any responsibility for the use of the manual.

Flexicon A/S reserves the right to revise the manual and make periodical changes to the content without any obligation to inform any holders of such revision or change