

Operator's manual FC32



1	Declaration of conformity	3
2	Caution	4
3	General information	5
3.1	Unpacking and inspection	5
4	Installation	6
5	Operation	7
5.1	Adjusting the height	7
5.2	External torque adjustment	8
5.3	Changing the screw head	9
5.4	Change of bottle grip.....	9
6	Daily use	10
7	Accessories	11
8	Daily cleaning	11
8.1	Maintenance	11
8.2	Disposal.....	11
9	Technical specifications.....	11
10	Annex A.....	12

1 Declaration of conformity

We Flexicon A/S
Frejasvej 2-6
DK-4100 Ringsted

Declare on our sole responsibility that the product:

FlexCap 32 - FC32

	
Model	FC32
Serial No.	"see label on product"
Supply	230V/50Hz/50W
Year	2007
	

To which this declaration relates is in conformity with the following standard(s):

DS/EN ISO 12100	Safety of machinery - Basic concepts, general principles of design
DS/EN 60204	Safety of machinery – Electrical equipment of machines

According to the provisions in the Directives:

98/37/EC	On the approximation of the laws of the Member States relating to machinery.
73/23/EEC	On the harmonization of the laws of Member States relating to electrical equipment designed for use within certain voltage limits
2004/108/EC	On the approximation of the laws of the Member States relating to electromagnetic compatibility

Signature:



January 2007

Ringsted, Denmark

Flemming Jørgensen

2 Caution

This manual should be read before using the FlexCap 32.

Explanations to the pictograms:

"Warning against touching"/ "Warning against dangerous part of the machine":



"Warning against high voltage":

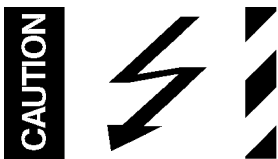

For each cap size there must be a custom designed screw head.

When adjusting the machine makes sure that the gab between the screw head and bottle cap is less than 3 mm.

The mains switch is used for emergency stopping.

FlexCap 32 should only be used for capping bottles.

The FlexCap 32 must be placed on a stable bedplate and in such a way, that it is not exposed to great humidity, high temperatures or other abnormal operating-environments. It is not to be used in explosion hazardous environments.

It is prohibited to maintain or clean the FlexCap 32, when it is connected to the power supply.

It is prohibited for unauthorised personnel to open the cover of the FlexCap 32's electrical parts. Always remember that the FlexCap 32 must be earthed by way of the switch.

3 General information

3.1 *Unpacking and inspection*

FlexCap 32 is a semiautomatic screw capping for bottles. By changing the screw head and bottle grip, different bottles can be capped with different cap sizes.

Please check that all items listed on the packing list have been received, and that no items were damaged during transport. In case of any defects or shortcomings, please contact Flexicon or your local supplier immediately.

When ordering spare parts or accessories for the FlexCap 32, please state serial number. The serial number is stamped on a label on the rear of FlexCap 32.

4 Installation

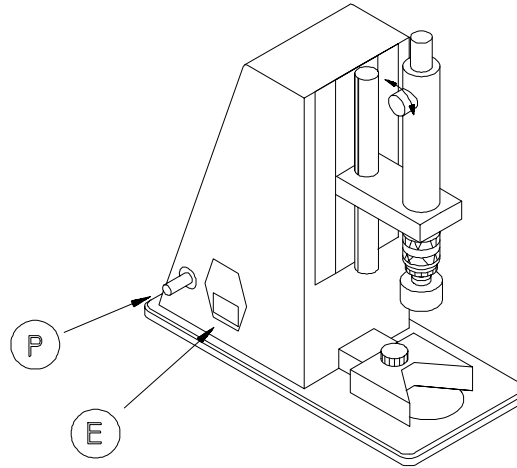

Fig. 4.1

Please check that, the machine is made for your local power supply. The sign on the machine indicates the value of power (110/120 VAC or 220/240 VAC). The frequency has no influence.

If the delivered power cable does not match your plug, the power cable is mounted in the right plug. The cable must be mounted as following:

Braun	Phase
Blue	Neutral
Yellow/Green	Earth

Tab. 4.1

REMEMBER that the machine must always via the power plug be connected to the earth and connected to CLEAN and DRY compressed air.

Due to the safety it is imperative that the earth connection is correctly established.

The plug box (E) contains 2 pieces of fuses. When the cover of fuse box is removed 1 more fuse is found inside the machine.

Connect the 5-7 clean and dry compressed airs to the pipe stub (P). Connect the power to the plug box (E) and the machine is ready for use.

5 Operation

5.1 Adjusting the height

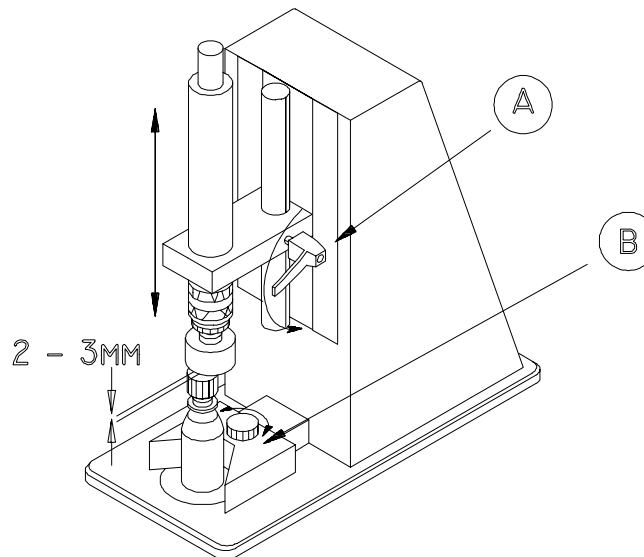

Fig. 5.1

When the power and air is connected, the screw unit with screw head is in the upper position. Place a bottle with cap (the cap just pre screwed as during operation) on the foot of the machine. By loosening the finger screw (A) the position of the screw unit can be adjusted. Make sure that the screw head is just 2 - 3 mm above the cap. The bottle grip (B) must be adjusted, so the unit gets activated, when the bottle is under the centre of the screw unit.

5.2 External torque adjustment

The clutch casing sleeve (C) is pushed down, and the screw head is rotated until the hole in the adjustment lock plate is visible through the slot. The torque of the cap can then be increased by inserting a Phillips screw driver and rotating it clockwise. Rotating the screw driver counter clockwise will decrease the torque.

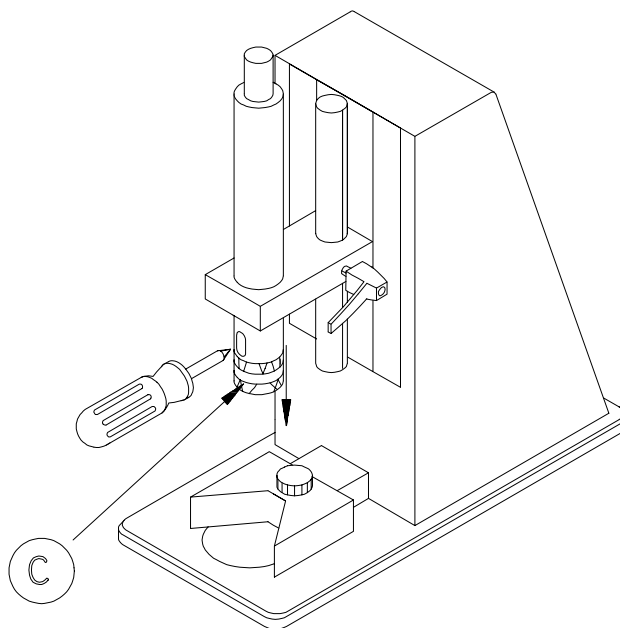

Fig. 5.2

5.3 Changing the screw head

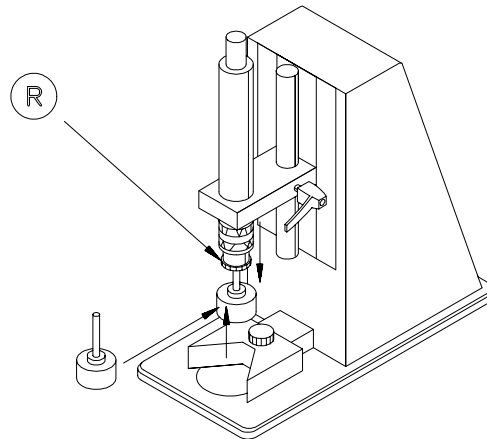

Fig. 5.3

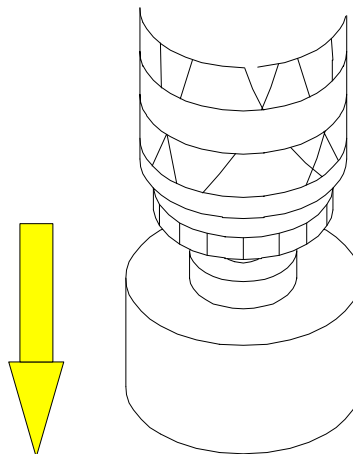

Fig. 5.4

Pull the spring-loaded release sleeve down, and pull at the same time the screw head down. The screw head will come off the quick change chuck.

For mounting the new screw head, press the head up in the quick change chuck. When the air supply is re-opened the unit is ready for operation with the new screw head, after adjustment of the height as described in section 5.1.

5.4 Change of bottle grip

The bottle grip can be released by unscrewing the finger screw fix the bottle grip to the arm. The new bottle grip is mounted with the finger screw, and adjusted as described in section 5.1.

6 Daily use

The bottle with cap (the cap just pre screwed) is placed in the bottle grip.

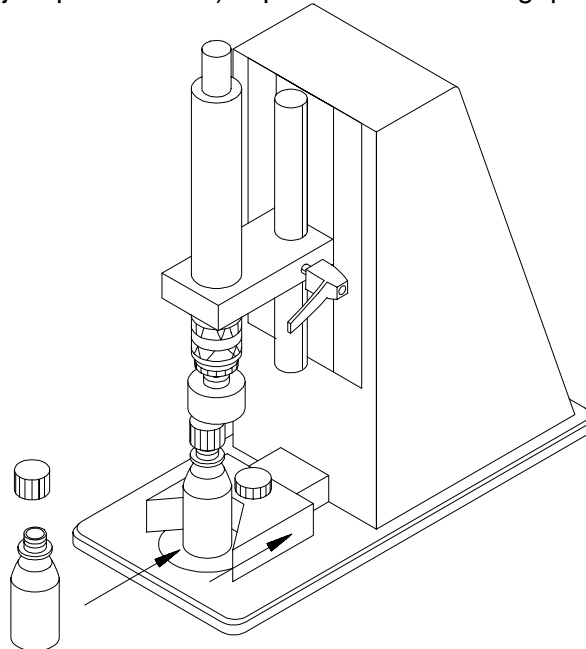

Fig. 6.1

When the bottle grip (B) is activated (by pushing it towards the rear of the machine), the screw unit go down and cap the bottle.

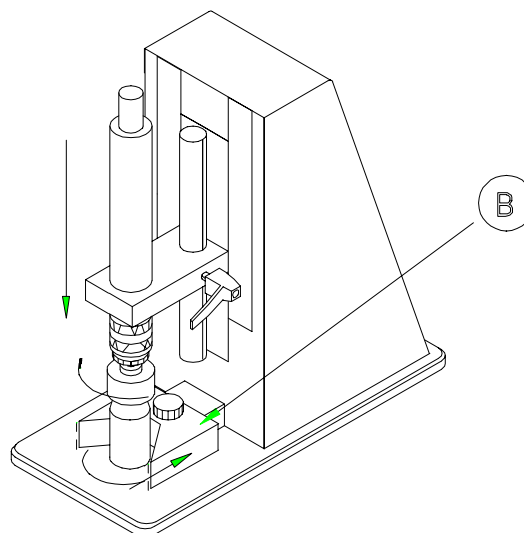

Fig. 6.2

7 Accessories

For each cap and bottle size a customised screw head as well as bottle grip is needed. Flexicon manufactures the screw heads and grip according to bottle and cap samples.

Accessories	
Screw head	89-110-010
Grip	89-115-050

8 Daily cleaning

Daily cleaning will not be necessary except for the normal routine cleaning of production equipment. Liquids must NOT be splashed onto FlexCap 32. It may only be cleaned with a damp piece of paper or cloth.

8.1 Maintenance

As all movable parts in FlexCap 32 are maintenance-free, no maintenance is required apart from normal cleaning of the equipment.

If service should be needed, please contact your supplier or Flexicon A/S.

8.2 Disposal

The machines can be disposed in the same way as Personal Computers.

9 Technical specifications

Power supply	110/240 VAC 50/60 Hz with earth	
Power consumes.	50 W max.	
Air supply	5 to 7 bar	
Air Capacity	150 l/min max	
Torque	Variable from 1 - 4 Nm	
Cap Size	Diameter. Ø65mm	Height 40 mm max.
Bottle size	Diameter. Ø15-100 mm	Height 240mm max.
Housing	Anodised aluminium	
Ingress Protection	IP31	
Weight	16 kg	
Order number	93-110-110	

Tab. 9.1

10 Annex A

Sound pressure level: LAeq < 70 dB(A)

COPYRIGHT

Copyright (c) 2007 Flexicon A/S. All rights to this manual belong to Flexicon A/S. Neither the complete manual nor parts of it may be translated, copied, printed or published in any form or by any means without permission in writing from Flexicon A/S

Flexicon A/S is convinced that the information of this manual is correct, but Flexicon A/S can not be held responsible for it.

Flexicon A/S reserves the right to update and amend this manual without previous notice. Flexicon A/S is under no obligation to update manuals already published.